



PARTS CATALOGUE

YZ125'07 (1C3C) SOUTH AFRICA

YZ125W1
YZ125W/YZ125
PARTS CATALOGUE
©2006 by Yamaha Motor Co., Ltd.
1st edition, June 2006
All rights reserved.
Any reprinting or unauthorized use
without the written permission of
Yamaha Motor Co., Ltd.
is expressly prohibited.

A3



A4

FOREWORD

This Parts Catalogue is related to the parts for the model(s) on the cover page. When you are ordering replacement parts, please refer to this Parts Catalogue and quote both part numbers and part names correctly.

1. Modifications or additions which have been made after the issue of the Parts Catalogue will be announced in the Parts News.

It is advisable that you make the necessary corrections to the Parts Catalogue according to the Parts News.

2. Abbreviations

The following abbreviations are used in this Parts Catalogue.

“UR” Use specified parts number.

“UN” Use as many as needed.

“AP” Alternate Parts

“LM” Locally Made (Parts need to be ordered locally)

“F#” Frame No. (Applicable machine No.)

“O/S” Over Size

3. The number of components for assembly

- Parts, which are to be supplied in an assembly, are listed with a dot (.) in front of the part name as shown below.
- The numeral appearing to the right of each component part indicates the quantity of parts for each assembly unit.

PART NO.	DESCRIPTION	Q'TY	REMARKS
2F5-83310-60	FRONT FLASHER LIGHT ASSY	2	
115-83311-60	.BULB (6V-18W)	1	

4. Applicable colours of graphics are represented in the “REMARKS” as shown below.

PART NO.	DESCRIPTION	Q'TY	REMARKS
2N4-24110-00-X5	FUEL TANK COMP.	2	MXR
3J1-24240-10	.GRAPHIC, FUEL TANK	1	FOR MXR

5. Note that the illustrations for reference in finding parts numbers are not to be used for assembling. When assembling, please use the applicable service manual.

6. The asterisk (*) before a reference number indicates modified items after the first edition.

FOREWORD

7. Applicable Serial No.

Engine Serial No.

Frame Serial No.

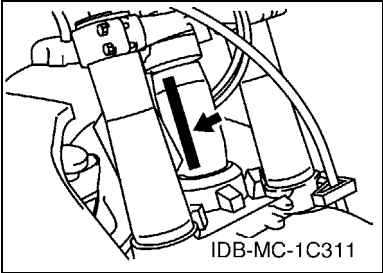
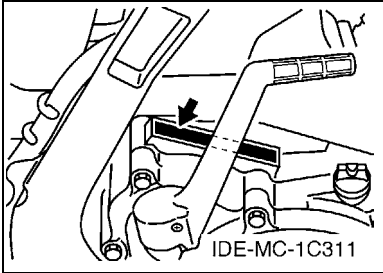

8. Applicable Colour Code (The (*) mark shows Model colour.)

Abbreviation	Colour Name	Colour Code
DPBSE(*)	DEEP PURPLISH BLUE SOLID E	0583

MODEL LABEL

(1) A label called "Model Label" is affixed in the location as indicated in (3) below. When using this parts catalogue, please be sure to cross-reference the "model code - production code No." in the catalogue with the "model code - production code No." indicated on the Model Label affixed onto the product concerned.

(2) "Model Label" Indication

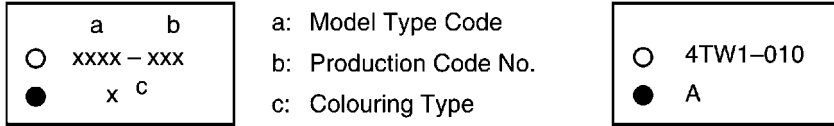

(3) Model Label Affixing Location

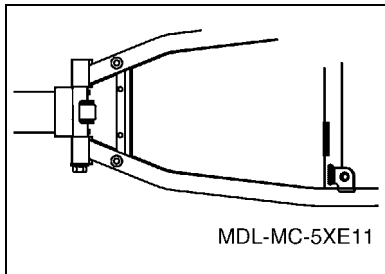

(4) Colouring Information

Model Code	Colouring Type Code	Colour Code	Colour Name	Abbreviation
1C39	A	0583	DEEP PURPLISH BLUE SOLID E	DPBSE
1C3A	A	0583	DEEP PURPLISH BLUE SOLID E	DPBSE
1C3B	A	0583	DEEP PURPLISH BLUE SOLID E	DPBSE
1C3C	A	0583	DEEP PURPLISH BLUE SOLID E	DPBSE

(5) Model Code - Production Code Number of Model Listed in This Parts Catalogue

Model Code	Production Code No.	Country (destination)	Model Code	Production Code No.	Country (destination)
1C39	010	U.S.A.			
	020	CANADA			
1C3A	010	EUROPE			
1C3B	010	JAPAN			
1C3C	010	AUSTRALIA			
		NEW ZEALAND			
	020	SOUTH AFRICA			

CONTENTS

ENGINE

CYLINDER HEAD	B2
GOVERNOR	B4
CRANKSHAFT & PISTON	B5
WATER PUMP	B6
RADIATOR & HOSE	B7
INTAKE	B8
CARBURETOR	B9
EXHAUST	B12
CRANKCASE	B14
CRANKCASE COVER 1	B15
STARTER	C2
CLUTCH	C3
TRANSMISSION	C4
SHIFT CAM & FORK	C6
SHIFT SHAFT	C7

CHASSIS

FRAME	C8
FENDER	C10
SIDE COVER	C12
REAR ARM	C13
REAR SUSPENSION	C15
STEERING	D3
FRONT FORK	D4
FUEL TANK	D7
SEAT	D9
FRONT WHEEL	D10
FRONT BRAKE CALIPER	D11
REAR WHEEL	D12
REAR BRAKE CALIPER	D14
STEERING HANDLE & CABLE	D15
FRONT MASTER CYLINDER	E2
STAND & FOOTREST	E3
REAR MASTER CYLINDER	E4
GENERATOR	E5
HANDLE SWITCH & LEVER	E6
ELECTRICAL 1	E7
ALTERNATE FOR CHASSIS	E8
OPTIONAL PARTS 1	E9

INDEX

NUMERICAL INDEX	M1
-----------------------	----

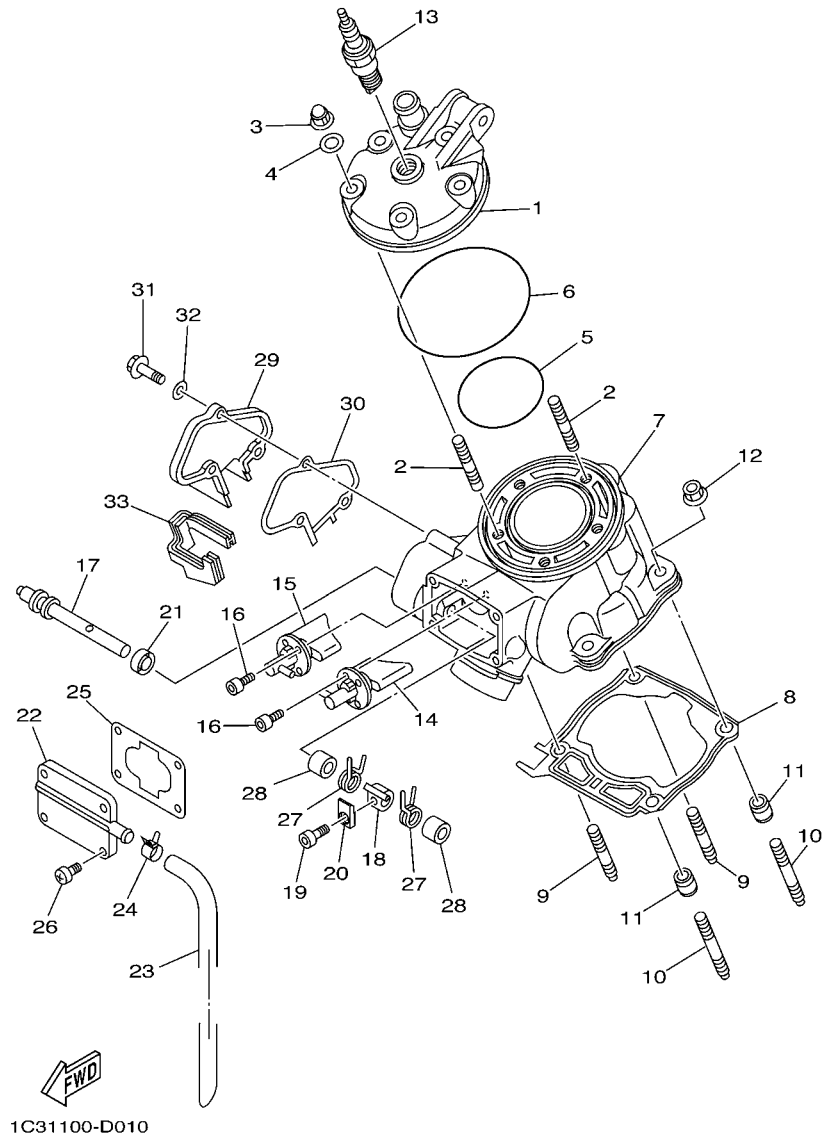
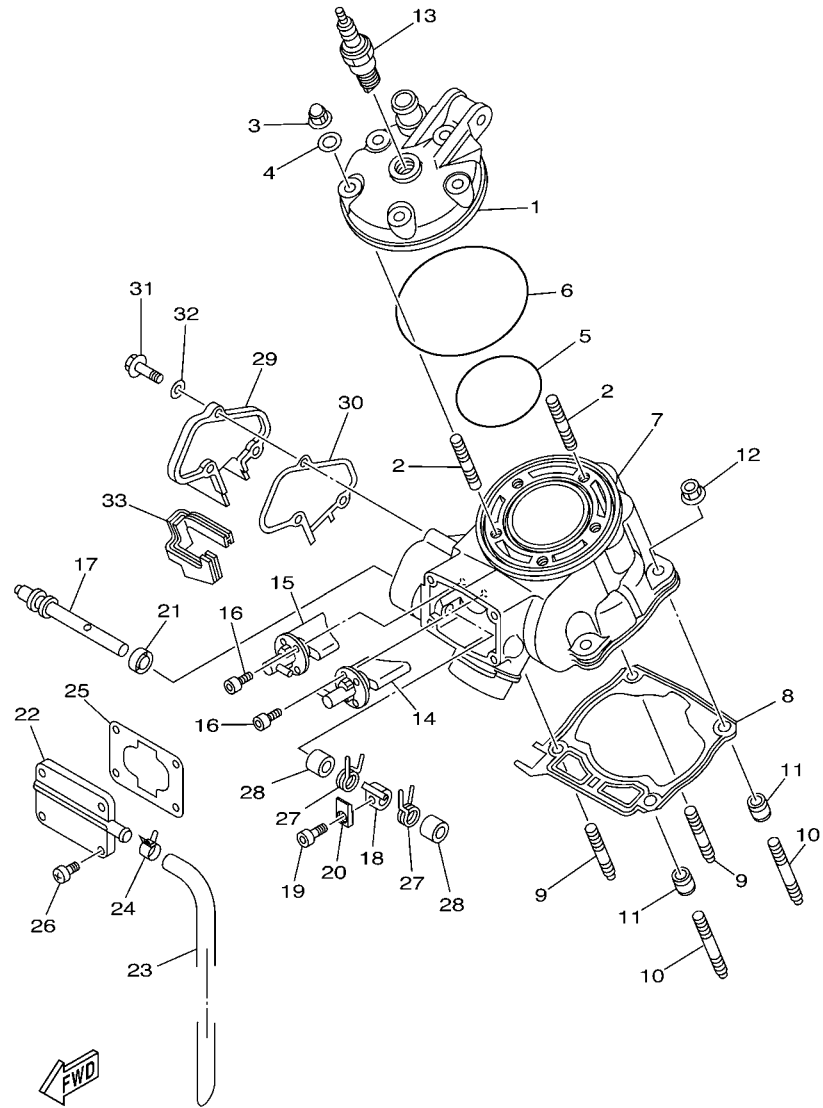

FIG. 1 CYLINDER HEAD

REF. NO.	PART NO.	DESCRIPTION	1C39	1C3A	1C3B	1C3C	REMARKS
1	1C3-11111-10	HEAD, CYLINDER 1	1	1	1	1	
2	90116-08027	BOLT, STUD	5	5	5	5	
3	90176-08005	NUT, CROWN	5	5	5	5	
4	90201-080L8	WASHER, PLATE	5	5	5	5	
5	93210-63442	O-RING	1	1	1	1	
6	93210-90785	O-RING	1	1	1	1	
7	1C3-11311-10	CYLINDER 1	1	1	1	1	
8	1C3-11351-00	GASKET, CYLINDER	1	1	1	1	
9	90116-08031	BOLT, STUD	2	2	2	2	
10	90116-08028	BOLT, STUD	2	2	2	2	
11	99590-10114	PIN, DOWEL	2	2	2	2	
12	90179-08019	NUT	4	4	4	4	
13	94702-00193	PLUG, SPARK (NGK BR9EVX)	1	1		1	
14	1C3-1131D-00	VALVE ASSY	1	1	1	1	
15	1C3-1132D-00	VALVE ASSY 2	1	1	1	1	
16	91312-05012	BOLT	4	4	4	4	
17	5HD-1131V-00	SHAFT 1	1	1	1	1	
18	4SS-11832-00	LEVER, LINK	1	1	1	1	
19	91312-04010	BOLT	1	1	1	1	
20	5UN-11395-00	HOLDER	1	1	1	1	
21	93104-08040	OIL SEAL	1	1	1	1	
22	4SS-1131M-01	COVER	1	1	1	1	
23	4JY-11166-00	PIPE, BREATHER 1	1	1	1	1	
24	90467-13062	CLIP	1	1	1	1	
25	1C3-11354-00	GASKET	1	1	1	1	
26	98902-05016	SCREW, BIND	4	4	4	4	

FIG. 1 CYLINDER HEAD



1C31100-D010

REF. NO.	PART NO.	DESCRIPTION	1C39	1C3A	1C3B	1C3C	REMARKS
27	90508-16134	SPRING, TORSION	2	2	2	2	
28	90387-08785	COLLAR	2	2	2	2	
29	1C3-11992-00	HOUSING 2	1	1	1	1	
30	1C3-11993-00	GASKET	1	1	1	1	
31	97002-05016	BOLT	3	3	3	3	
32	92902-05600	WASHER, PLATE	3	3	3	3	
33	1C3-11995-00	SEAL, HOUSING	1	1	1	1	

FIG. 2 GOVERNOR

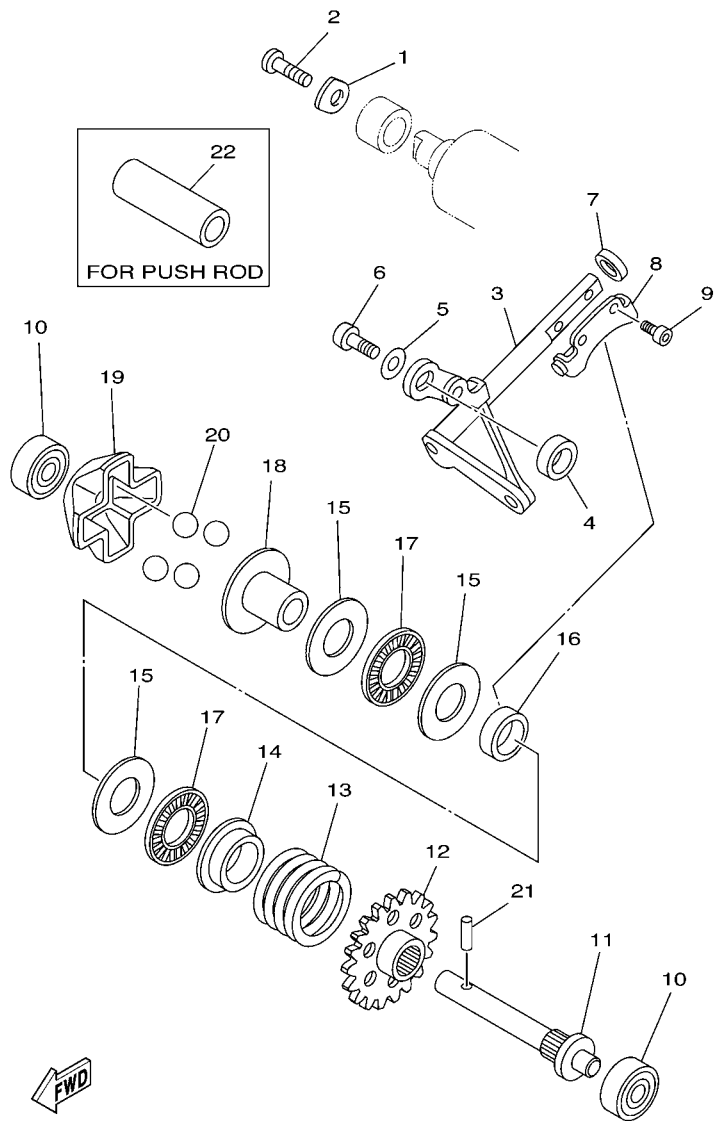

5NY1100-A020

REF. NO.	PART NO.	DESCRIPTION	1C39	1C3A	1C3B	1C3C	REMARKS
1	4JY-11915-10	PLATE, THRUST 1	1	1	1	1	
2	98502-05012	SCREW, PAN HEAD	1	1	1	1	
3	1C3-11990-10	PUSH ROD ASSY	1	1	1	1	
4	90387-085E1	COLLAR	1	1	1	1	
5	90201-05021	WASHER, PLATE	1	1	1	1	
6	97002-05012	BOLT	1	1	1	1	
7	93104-08040	OIL SEAL	1	1	1	1	
8	3JE-11922-01	FORK, GOVERNOR	1	1	1	1	
9	91312-04006	BOLT	2	2	2	2	
10	93300-60801	BEARING	2	2	2	2	KOYO
11	5X4-11921-02	SHAFT, GOVERNOR	1	1	1	1	
12	5NY-11953-00	GEAR, GOVERNOR	1	1	1	1	
13	90501-300A0	SPRING, COMPRESSION	1	1	1	1	
14	5CU-11952-00	PLATE	1	1	1	1	
15	90201-150U6	WASHER, PLATE	3	3	3	3	
16	90387-152F2	COLLAR	1	1	1	1	
17	93340-21505	BEARING	2	2	2	2	
18	5CU-11912-00	RETAINER, WEIGHT	1	1	1	1	
19	5CU-11911-00	RETAINER	1	1	1	1	
20	93507-16020	BALL	4	4	4	4	
21	93603-14240	PIN, DOWEL	1	1	1	1	
22	90387-107T9	COLLAR	1	1	1	1	AP

FIG. 3 CRANKSHAFT & PISTON

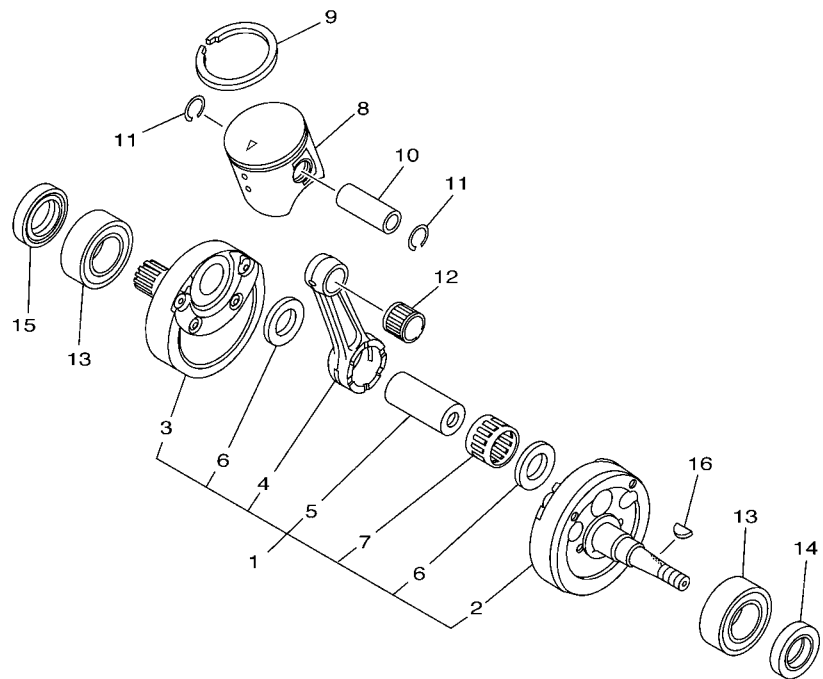

REF. NO.	PART NO.	DESCRIPTION	1C39	1C3A	1C3B	1C3C	REMARKS
1	1C3-11400-20	CRANKSHAFT ASSY	1	1	1	1	
2	1C3-11410-10	.CRANKSHAFT	1	1	1	1	
3	1C3-11420-20	.CRANKSHAFT	1	1	1	1	
4	1C3-11651-00	.ROD, CONNECTING	1	1	1	1	
5	3JD-11681-10	.PIN, CRANK 1	1	1	1	1	
6	90209-22326	.WASHER	2	2	2	2	
7	93310-52238	.BEARING	1	1	1	1	
8	1C3-11631-01-A0	PISTON (STD)	1	1	1	1	UR RED
	1C3-11631-01-B0	PISTON (STD)	1	1	1	1	UR ORANGE
	1C3-11631-01-C0	PISTON (STD)	1	1	1	1	UR GREEN
	1C3-11631-01-D0	PISTON (STD)	1	1	1	1	UR PURPLE
9	5NY-11611-00	RING, PISTON	1	1	1	1	
10	1C3-11633-00	PIN, PISTON	1	1	1	1	
11	93450-16068	CIRCLIP	2	2	2	2	
12	93310-21510	BEARING	1	1	1	1	
13	93306-37204	BEARING	2	2	2	2	KOYO
14	93102-20485	OIL SEAL	1	1	1	1	
15	93102-22419	OIL SEAL	1	1	1	1	
16	90280-03017	KEY, WOODRUFF	1	1	1	1	



5NY1100-A030

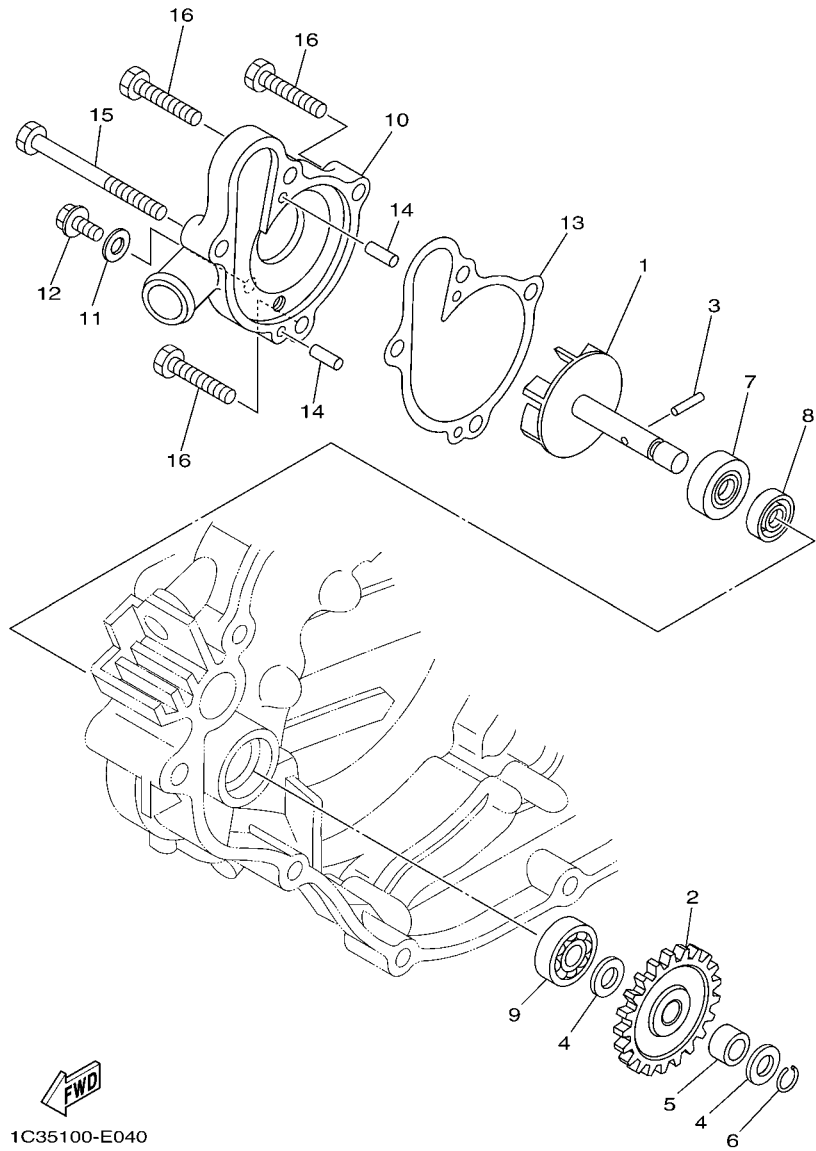

1C35100-E040

FIG. 4 WATER PUMP

REF. NO.	PART NO.	DESCRIPTION	1C39	1C3A	1C3B	1C3C	REMARKS
1	1C3-12450-00	IMPELLER SHAFT ASSY	1	1	1	1	
2	1C3-12453-10	GEAR	1	1	1	1	
3	93603-12007	PIN, DOWEL	1	1	1	1	
4	90201-08512	WASHER, PLATE	2	2	2	2	
5	90387-08032	COLLAR	1	1	1	1	
6	93440-07182	CIRCLIP	1	1	1	1	
7	93102-08004	OIL SEAL	1	1	1	1	
8	93102-08307	OIL SEAL	1	1	1	1	
9	93300-60801	BEARING	1	1	1	1	UR KOYO
	93300-60814	BEARING	1	1	1	1	UR NMB
10	1C3-12422-00	COVER, HOUSING	1	1	1	1	
11	90430-06014	GASKET	1	1	1	1	
12	95022-06010	BOLT, FLANGE	1	1	1	1	
13	1C3-12428-00	GASKET, HOUSING COVER 2	1	1	1	1	
14	93604-10011	PIN, DOWEL	2	2	2	2	
15	95022-06065	BOLT, FLANGE	1	1	1	1	
16	95022-06025	BOLT, FLANGE	3	3	3	3	

FIG. 5 RADIATOR & HOSE

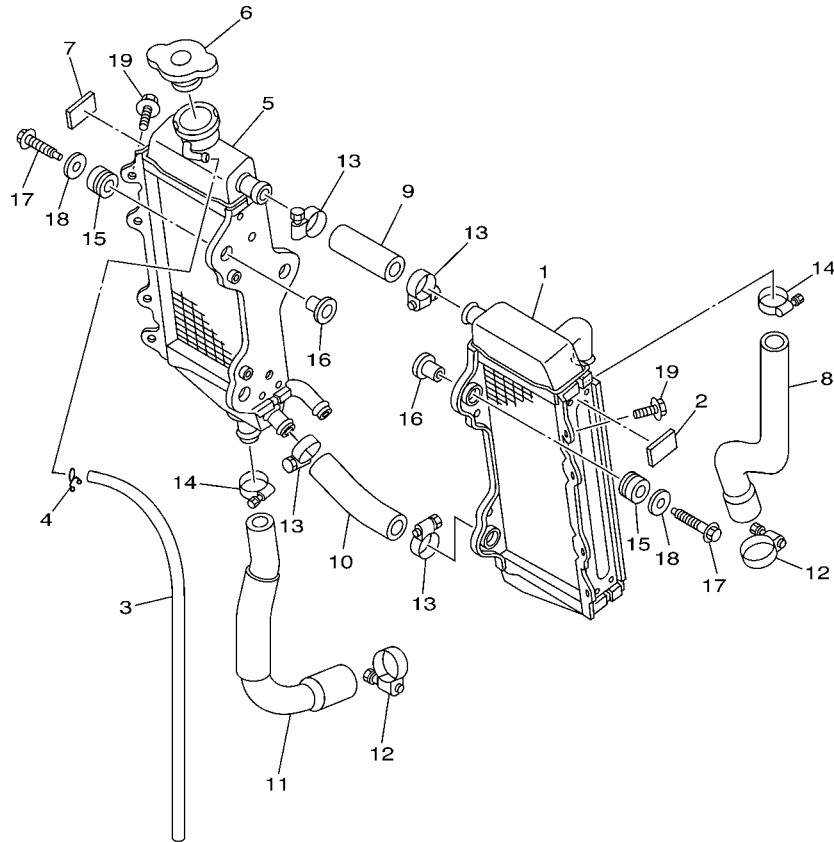

1C31100-D050

REF. NO.	PART NO.	DESCRIPTION	1C39	1C3A	1C3B	1C3C	REMARKS
1	1C3-1240A-00	RADIATOR ASSY	1	1	1	1	
2	1C3-12465-00	DAMPER, RADIATOR	1	1	1	1	
3	91A20-05065	TUBE, FLEXIBLE VINYL	1	1	1	1	
4	90467-090A2	CLIP	1	1	1	1	
5	1C3-12461-00	RADIATOR ASSY	1	1	1	1	
6	22W-12462-00	CAP, RADIATOR	1	1	1	1	
7	1C3-12465-00	DAMPER, RADIATOR	1	1	1	1	
8	1C3-12481-00	PIPE 1	1	1	1	1	
9	1C3-12482-00	PIPE 2	1	1	1	1	
10	1C3-12483-00	PIPE 3	1	1	1	1	
11	1C3-12484-00	PIPE 4	1	1	1	1	
12	90450-28001	HOSE CLAMP ASSY	2	2	2	2	
13	90450-22001	HOSE CLAMP ASSY	4	4	4	4	
14	90450-25001	HOSE CLAMP ASSY	2	2	2	2	
15	90480-15528	GROMMET	6	6	6	6	
16	90387-06065	COLLAR	6	6	6	6	
17	90105-06111	BOLT, FLANGE	6	6	6	6	
18	90201-06571	WASHER, PLATE	6	6	6	6	
19	90105-06118	BOLT, FLANGE	2	2	2	2	

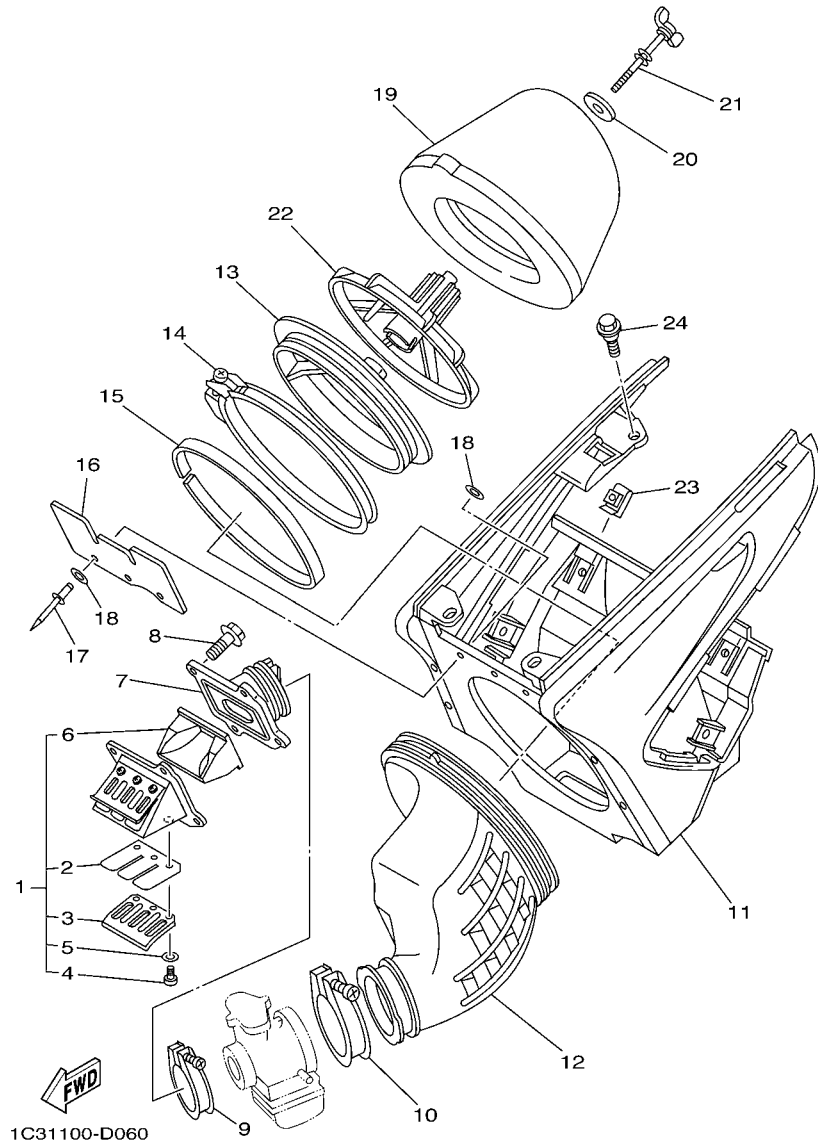

FIG. 6 INTAKE

REF. NO.	PART NO.	DESCRIPTION	1C39	1C3A	1C3B	1C3C	REMARKS
1	1C3-13610-10	REED VALVE ASSY	1	1	1	1	
2	5UN-13613-00	.REED, VALVE	2	2	2	2	
3	5MV-13616-10	.STOPPER, REED VALVE	2	2	2	2	
4	98502-03006	.SCREW, PAN HEAD	6	6	6	6	
5	92902-03100	.WASHER	6	6	6	6	
6	1C3-13625-00	.SPACER, REED VALVE	1	1	1	1	
7	1C3-13565-00	JOINT, CARBURETOR	1	1	1	1	
8	95022-06020	BOLT, FLANGE	4	4	4	4	
9	90450-54007	HOSE CLAMP ASSY	1	1	1	1	
10	90450-70002	HOSE CLAMP ASSY	1	1	1	1	
11	5NY-14401-01	AIR CLEANER CASE ASSY	1	1	1	1	
12	1C3-14453-10	JOINT, AIR CLEANER 1	1	1	1	1	
13	5NY-14459-00	HOLDER, GUIDE	1	1	1	1	
14	5NY-14455-20	BAND	1	1	1	1	
15	5NY-14442-00	SPACER	1	1	1	1	
16	5NY-14417-00	COVER 1	1	1	1	1	
17	90267-32070	RIVET, BLIND	3	3	3	3	
18	90201-03313	WASHER, PLATE	6	6	6	6	
19	4XM-14451-00	ELEMENT, AIR CLEANER	1	1	1	1	
20	90209-06096	WASHER	1	1	1	1	
21	90122-06005	BOLT, WING	1	1	1	1	
22	3JD-14458-01	GUIDE	1	1	1	1	
23	90183-06023	NUT, SPRING	4	4	4	4	
24	90109-067F4	BOLT	4	4	4	4	

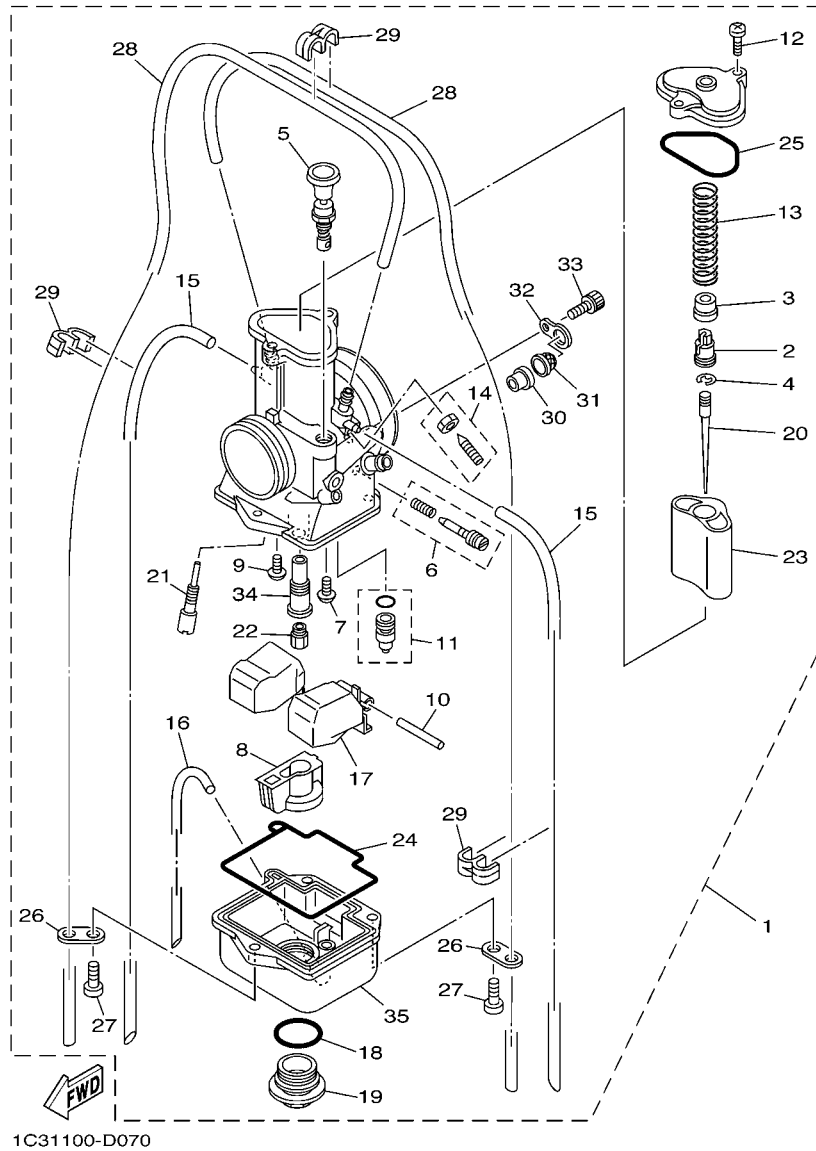
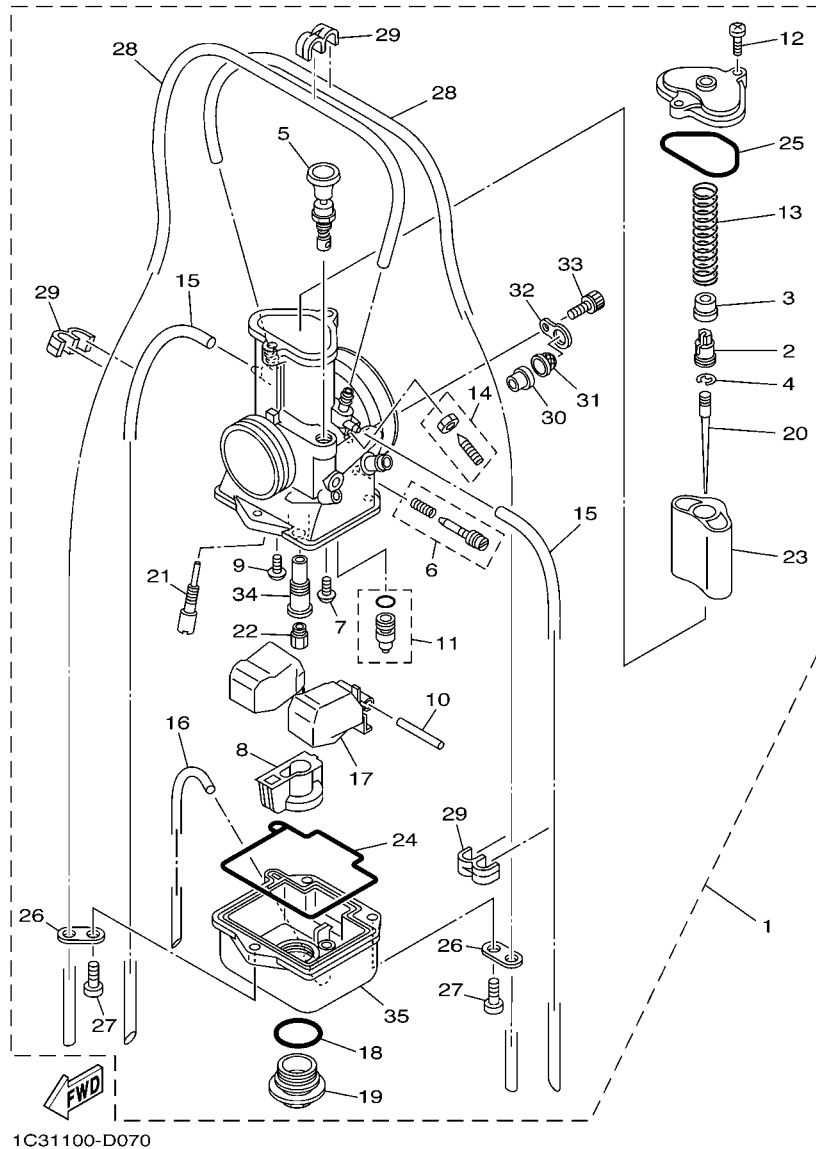

FIG. 7 CARBURETOR

REF. NO.	PART NO.	DESCRIPTION	1C39	1C3A	1C3B	1C3C	REMARKS
1	1C3-14101-30	CARBURETOR ASSY 1	1				
	1C3-14101-40	CARBURETOR ASSY 1		1			
	1C3-14101-50	CARBURETOR ASSY 1			1	1	
2	5HD-14261-00	.HOLDER	1	1	1	1	
3	4PE-14194-00	.RING	1	1	1	1	
4	3MA-14159-00	.CLIP	1	1	1	1	
5	3JE-14171-00	.PLUNGER, STARTER	1	1	1	1	
6	5UN-14104-00	.AIR SCREW SET	1	1	1	1	
7	1FN-14565-00	.SCREW	1	1	1	1	
8	5ET-14261-01	.HOLDER	1	1	1	1	
9	98507-04008	.SCREW, PAN HEAD	1	1	1	1	
10	353-14186-00	.PIN, FLOAT	1	1	1	1	
11	4PE-14107-38	.NEEDLE VALVE SET	1	1	1	1	
12	98507-04014	.SCREW, PAN HEAD	2	2	2	2	
13	4PE-14131-00	.SPRING, THROTTLE VALVE	1	1	1	1	
14	4PE-14103-00	.THROTTLE SCREW SET	1	1	1	1	
15	5ET-14197-00	.PIPE	2	2	2	2	
16	10V-14196-00	.PIPE	1	1	1	1	
17	5ET-14185-00	.FLOAT	1	1	1	1	
18	2K6-14147-00	.O-RING	1	1	1	1	
19	5ET-14115-00	.PLUG, SCREW	1	1	1	1	
20	284-14116-J4	.NEEDLE (6BFY42-74)				1	STD
	284-14116-H2	.NEEDLE (6BFY42-72)	1	1	1	1	AP
	284-14116-H3	.NEEDLE (6BFY42-73)	1	1	1	1	AP
	284-14116-H4	.NEEDLE (6BFY42-74)		1	1	1	AP
	284-14116-H5	.NEEDLE (6BFY42-75)	1	1	1	1	AP



1C31100-D070

FIG. 7 CARBURETOR

REF. NO.	PART NO.	DESCRIPTION	1C39	1C3A	1C3B	1C3C	REMARKS
20	284-14116-H6	.NEEDLE (6BFY42-76)	1	1	1	1	AP
	284-14116-J2	.NEEDLE (6BFY43-72)	1	1	1	1	AP
	284-14116-J3	.NEEDLE (6BFY43-73)	1	1	1	1	AP
	284-14116-J5	.NEEDLE (6BFY43-75)	1	1	1	1	AP
	284-14116-J6	.NEEDLE (6BFY43-76)	1	1	1	1	AP
	284-14116-K2	.NEEDLE (6BFY44-72)	1	1	1	1	AP
	284-14116-K3	.NEEDLE (6BFY44-73)	1	1	1	1	AP
	284-14116-K4	.NEEDLE (6BFY44-74)	1	1	1	1	AP
	284-14116-K5	.NEEDLE (6BFY44-75)	1	1	1	1	AP
	284-14116-K6	.NEEDLE (6BFY44-76)	1	1	1	1	AP
21	4KM-14142-45	.JET, PILOT (# 45)				1	STD
	4KM-14142-30	.JET, PILOT (# 30)	1	1	1	1	AP
	4KM-14142-32	.JET, PILOT (# 32.5)	1	1	1	1	AP
	4KM-14142-35	.JET, PILOT (# 35)	1	1	1	1	AP
	4KM-14142-37	.JET, PILOT (# 37.5)	1	1	1	1	AP
	4KM-14142-40	.JET, PILOT (# 40)				1	AP
	4KM-14142-42	.JET, PILOT (# 42.5)	1	1	1	1	AP
	4KM-14142-45	.JET, PILOT (# 45)	1	1	1	1	AP
	4KM-14142-47	.JET, PILOT (# 47.5)	1	1	1	1	AP
	4KM-14142-50	.JET, PILOT (# 50)	1	1	1	1	AP
22	137-14143-86	.JET, MAIN (#430)				1	STD
	137-14143-80	.JET, MAIN (#400)	1	1	1	1	AP
	137-14143-82	.JET, MAIN (#410)		1	1	1	AP
	137-14143-84	.JET, MAIN (#420)	1	1	1	1	AP

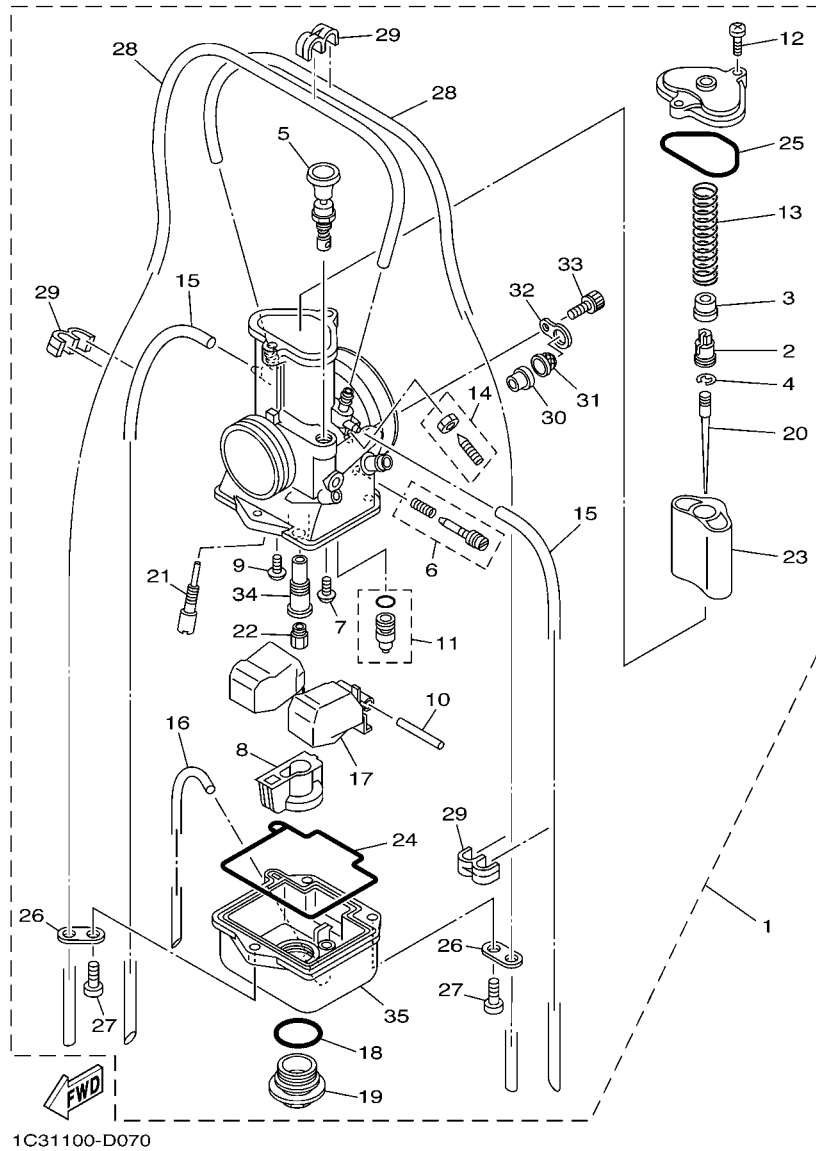
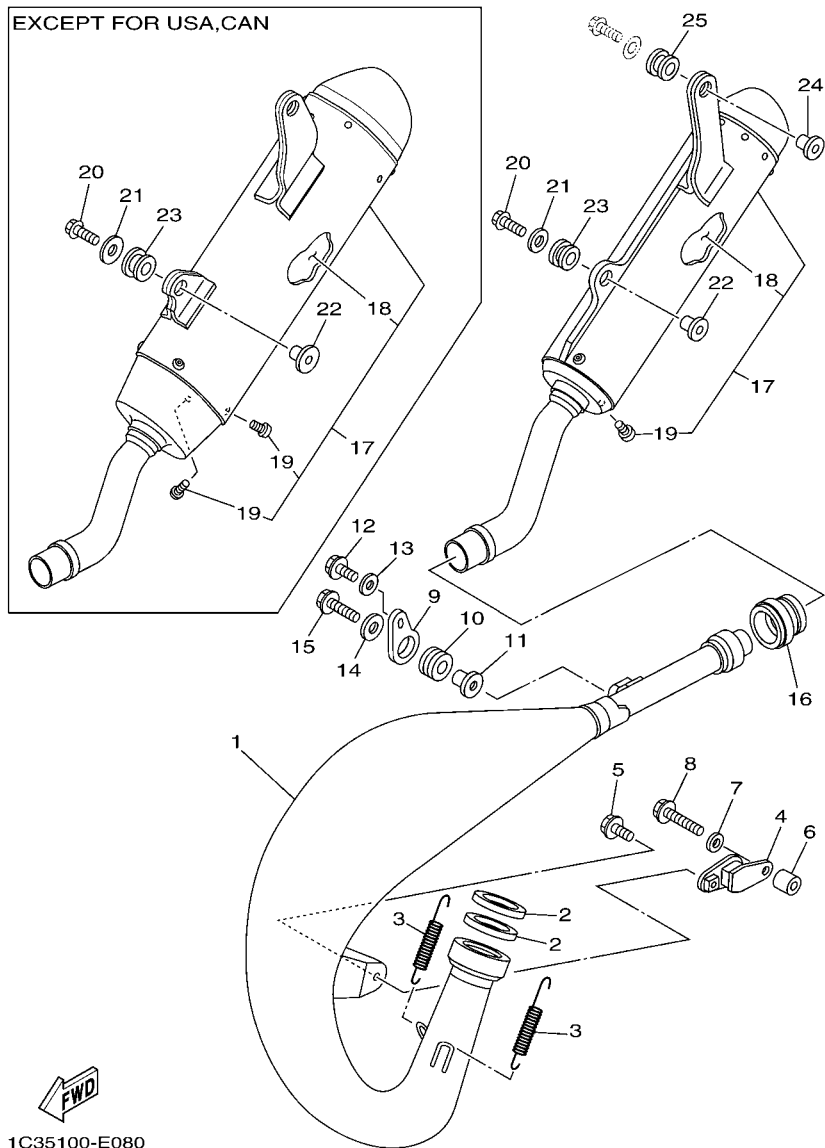

FIG. 7 CARBURETOR

REF. NO.	PART NO.	DESCRIPTION	1C39	1C3A	1C3B	1C3C	REMARKS
22	137-14143-86	.JET, MAIN (#430)	1				AP
	137-14143-88	.JET, MAIN (#440)	1	1	1	1	AP
	137-14143-90	.JET, MAIN (#450)	1	1	1	1	AP
	137-14143-92	.JET, MAIN (#460)	1	1	1	1	AP
	137-14143-94	.JET, MAIN (#470)	1	1	1	1	AP
23	1C3-14112-40	.VALVE, THROTTLE 1 (4.0)	1	1	1	1	STD
	1C3-14112-42	.VALVE, THROTTLE 1 (4.25)	1	1	1	1	AP
24	5ET-1416A-00	.O-RING	1	1	1	1	
25	5ET-14147-00	.O-RING	1	1	1	1	
26	51R-14146-00	.PLATE	2	2	2	2	
27	98502-05014	.SCREW, PAN HEAD	3	3	3	3	
28	2HH-14197-00	.PIPE	2	2	2	2	
29	87M-14137-00	.CLIP	3	3	3	3	
30	5MV-14194-00	.RING	1	1	1	1	
31	5MV-24514-00	.NET, FILTER 1	1	1	1	1	
32	5MV-14146-00	.PLATE	1	1	1	1	
33	5MV-14216-00	.SCREW	1	1	1	1	
34	5MV-14261-00	.HOLDER	1	1	1	1	
35	5NY-14181-00	.BODY, FLOAT CHAMBER 1	1	1	1	1	

EXCEPT FOR USA,CAN



1C35100-E080

FIG. 8 EXHAUST

REF. NO.	PART NO.	DESCRIPTION	1C39	1C3A	1C3B	1C3C	REMARKS
1	1C3-14610-00	EXHAUST PIPE ASSY 1	1	1	1	1	
2	5MV-14642-00	SEAL, EXHAUST	2	2	2	2	
3	90506-20018	SPRING, TENSION	2	2	2	2	
4	565-14771-00	STAY, MUFFLER 1	1	1	1	1	
5	95022-06012	BOLT, FLANGE	1	1	1	1	
6	1C3-14763-00	SPACER	1	1	1	1	
7	90201-06077	WASHER, PLATE	1	1	1	1	
8	95022-06025	BOLT, FLANGE	1	1	1	1	
9	5CU-14771-01	STAY, MUFFLER 1	1	1	1	1	
10	90480-16561	GROMMET	1	1	1	1	
11	90387-063G3	COLLAR	1	1	1	1	
12	95022-06014	BOLT, FLANGE	1	1	1	1	
13	90201-06078	WASHER, PLATE	1	1	1	1	
14	90201-06033	WASHER, PLATE	1	1	1	1	
15	95022-06025	BOLT, FLANGE	1	1	1	1	
16	4JY-14615-00	JOINT, EXHAUST 1	1	1	1	1	
17	1C3-14753-00	SILENCER, EXHAUST				1	
18	1C3-1469A-00	.FIBER				1	
19	92012-06010	.BOLT, BUTTON HEAD				4	
20	95022-06030	BOLT, FLANGE	1	1	1	1	
21	90201-06086	WASHER, PLATE				1	
22	90387-06121	COLLAR				1	

EXCEPT FOR USA,CAN

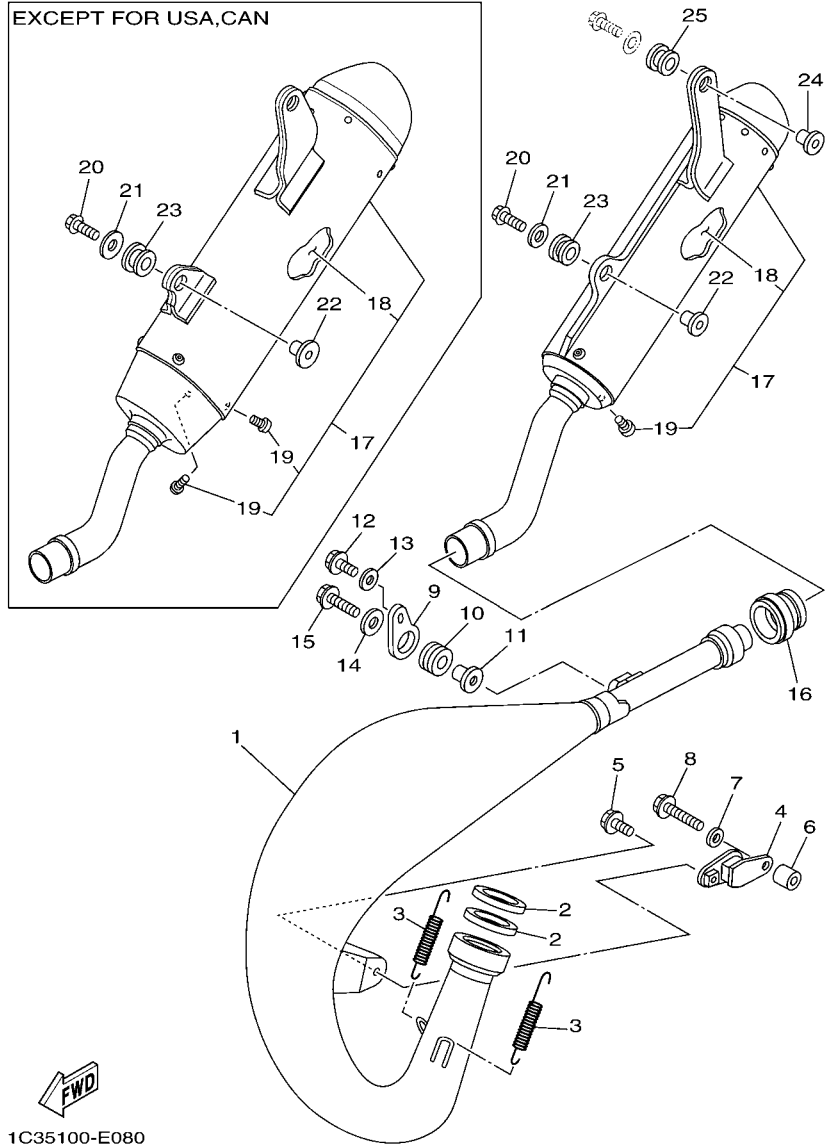

1C35100-E080

FIG. 8 EXHAUST

REF. NO.	PART NO.	DESCRIPTION	1C39	1C3A	1C3B	1C3C	REMARKS
23	90480-17004	GROMMET				1	
24	90387-06039	COLLAR	1	1	1	1	
25	90480-16404	GROMMET	1	1	1	1	

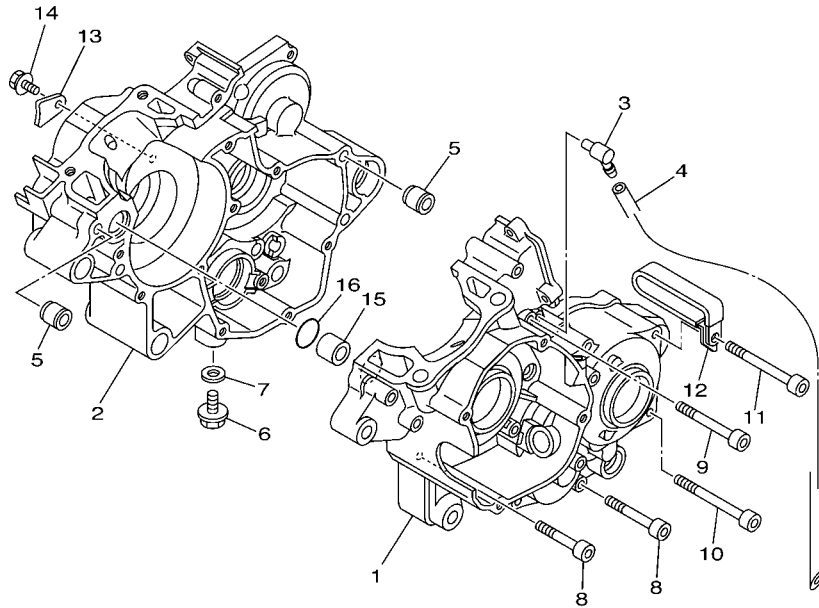
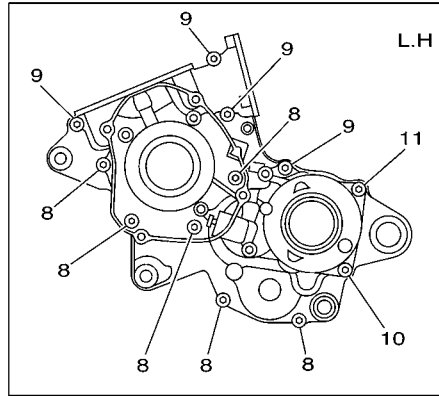

1C31100-D090

FIG. 9 CRANKCASE

REF. NO.	PART NO.	DESCRIPTION	1C39	1C3A	1C3B	1C3C	REMARKS
1	1C3-15111-01	CRANKCASE 1	1	1	1	1	
2	1C3-15121-00	CRANKCASE 2	1	1	1	1	
3	353-13115-01	CONNECTOR, SUCTION PIPE	1	1	1	1	
4	90445-08605	HOSE	1	1	1	1	
5	99530-10116	PIN, DOWEL	2	2	2	2	
6	95022-10016	BOLT, FLANGE	1	1	1	1	
7	90430-10188	GASKET	1	1	1	1	
8	91312-06045	BOLT	6	6	6	6	
9	91312-06055	BOLT	4	4	4	4	
10	91312-06065	BOLT	1	1	1	1	
11	91312-06075	BOLT	1	1	1	1	
12	90461-10136	CLAMP	1	1	1	1	
13	4V4-15118-00	HOLDER	1	1	1	1	
14	90105-06085	BOLT, FLANGE	1	1	1	1	
15	99590-17016	PIN, DOWEL	1	1	1	1	
16	93210-16314	O-RING	1	1	1	1	

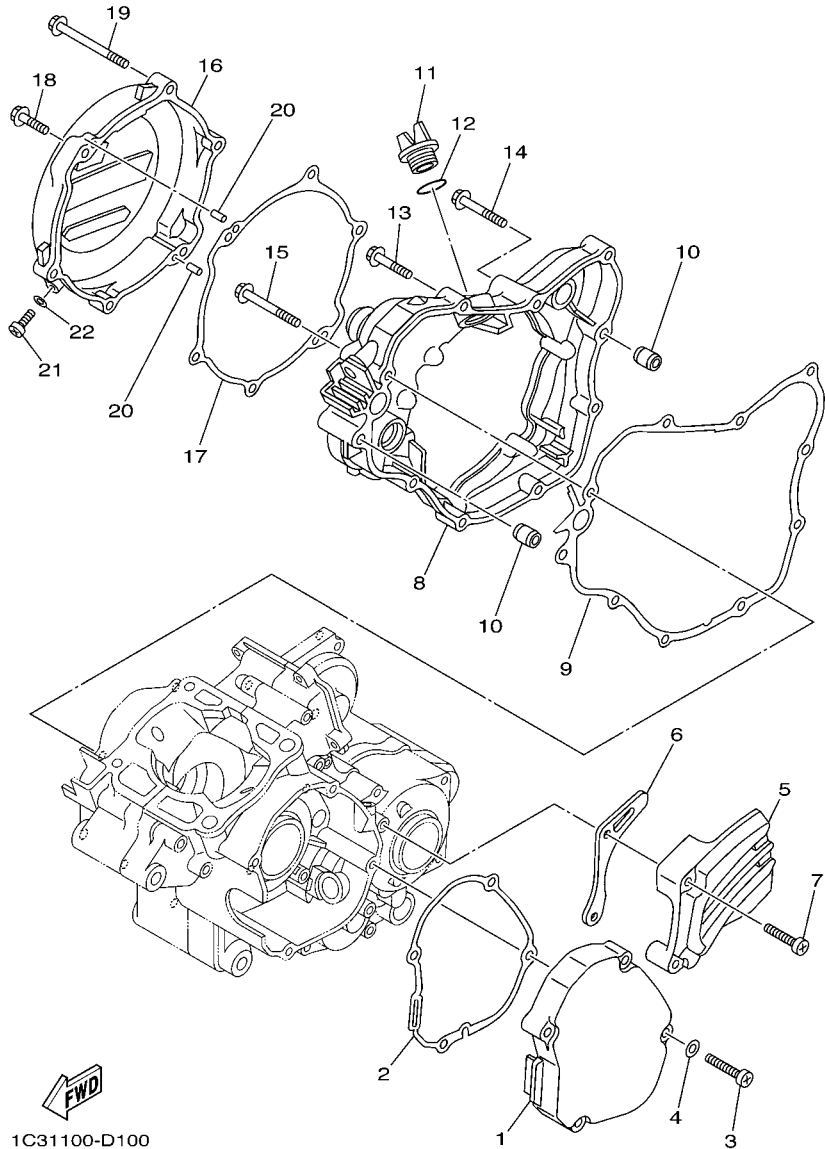

1C31100-D100

FIG. 10 CRANKCASE COVER 1

REF. NO.	PART NO.	DESCRIPTION	1C39	1C3A	1C3B	1C3C	REMARKS
1	1C3-15411-10	COVER, CRANKCASE 1	1	1	1	1	
2	1C3-15451-00	GASKET, CRANKCASE COVER 1	1	1	1	1	
3	92502-06030	SCREW, PAN HEAD	4	4	4	4	
4	92902-06600	WASHER, PLATE	4	4	4	4	
5	1C3-15421-10	COVER, CRANKCASE 2	1	1	1	1	
6	1C3-17466-00	GUIDE, CHAIN	1	1	1	1	
7	98502-06030	SCREW, PAN HEAD	2	2	2	2	
8	1C3-15431-00	COVER, CRANKCASE 3	1	1	1	1	
9	1C3-15462-00	GASKET, CRANKCASE COVER 3	1	1	1	1	
10	99530-08016	PIN, DOWEL	2	2	2	2	
11	3Y1-15363-00	PLUG, OIL	1	1	1	1	
12	93210-19123	O-RING	1	1	1	1	
13	95022-06030	BOLT, FLANGE	6	6	6	6	
14	95022-06040	BOLT, FLANGE	1	1	1	1	
15	95022-06050	BOLT, FLANGE	1	1	1	1	
16	1C3-15415-00	COVER, GENERATOR	1	1	1	1	
17	1C3-15463-00	GASKET, COVER PINION 2	1	1	1	1	
18	95022-06065	BOLT, FLANGE	1	1	1	1	
19	95022-06025	BOLT, FLANGE	5	5	5	5	
20	93604-10011	PIN, DOWEL	2	2	2	2	
21	92012-06012	BOLT, BUTTON HEAD	1	1	1	1	
22	90430-06014	GASKET	1	1	1	1	

FIG. 11 STARTER

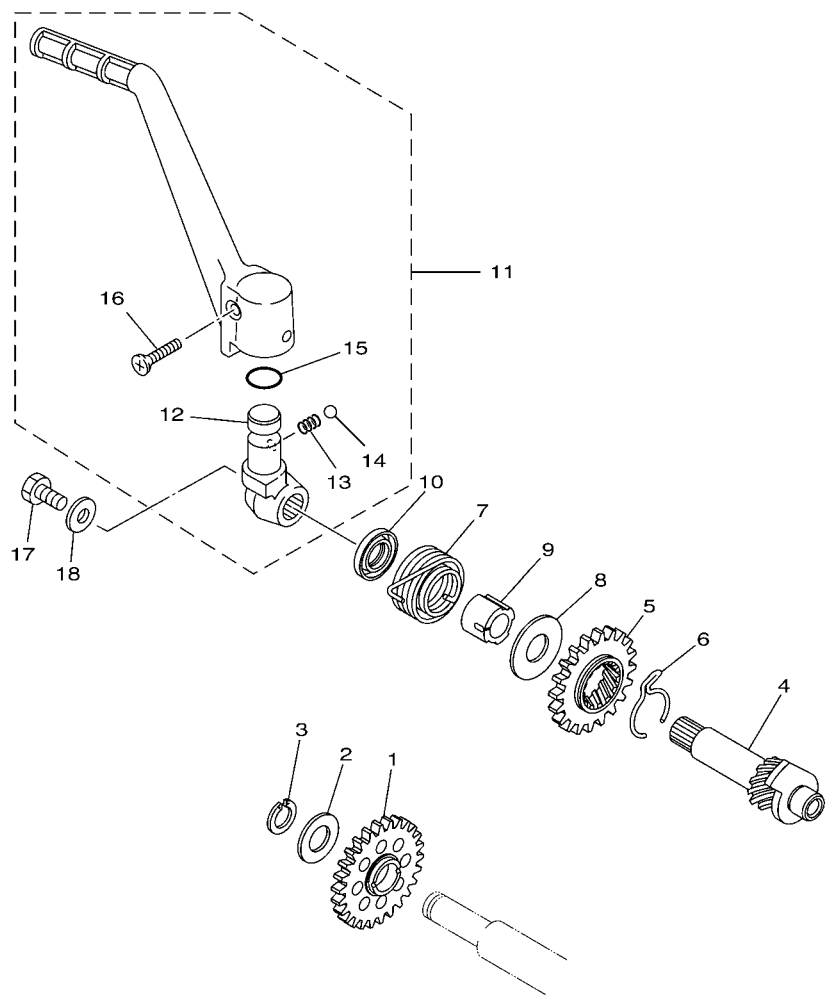

REF. NO.	PART NO.	DESCRIPTION	1C39	1C3A	1C3B	1C3C	REMARKS
1	1C3-15651-00	GEAR, KICK IDLE	1	1	1	1	
2	90201-175F6	WASHER, PLATE	1	1	1	1	
3	99009-17400	CIRCLIP	1	1	1	1	
4	1C3-15660-00	KICK AXLE ASSY	1	1	1	1	
5	1C3-15641-00	GEAR, KICK	1	1	1	1	
6	90468-26048	CLIP	1	1	1	1	
7	90508-26450	SPRING, TORSION	1	1	1	1	
8	90201-171G4	WASHER, PLATE	1	1	1	1	
9	1C3-15666-00	SPACER	1	1	1	1	
10	93102-17263	OIL SEAL	1	1	1	1	
11	4DB-15620-10	KICK CRANK ASSY	1	1	1	1	
12	4DB-15621-03	.BOSS, KICK CRANK	1	1	1	1	
13	90501-12081	.SPRING, COMPRESSION	1	1	1	1	
14	93507-32009	.BALL	1	1	1	1	
15	93210-15171	.O-RING	1	1	1	1	
16	90151-06045	.SCREW, COUNTERSUNK	1	1	1	1	
17	97022-06012	BOLT	1	1	1	1	
18	90201-06060	WASHER, PLATE	1	1	1	1	



1C31100-D110

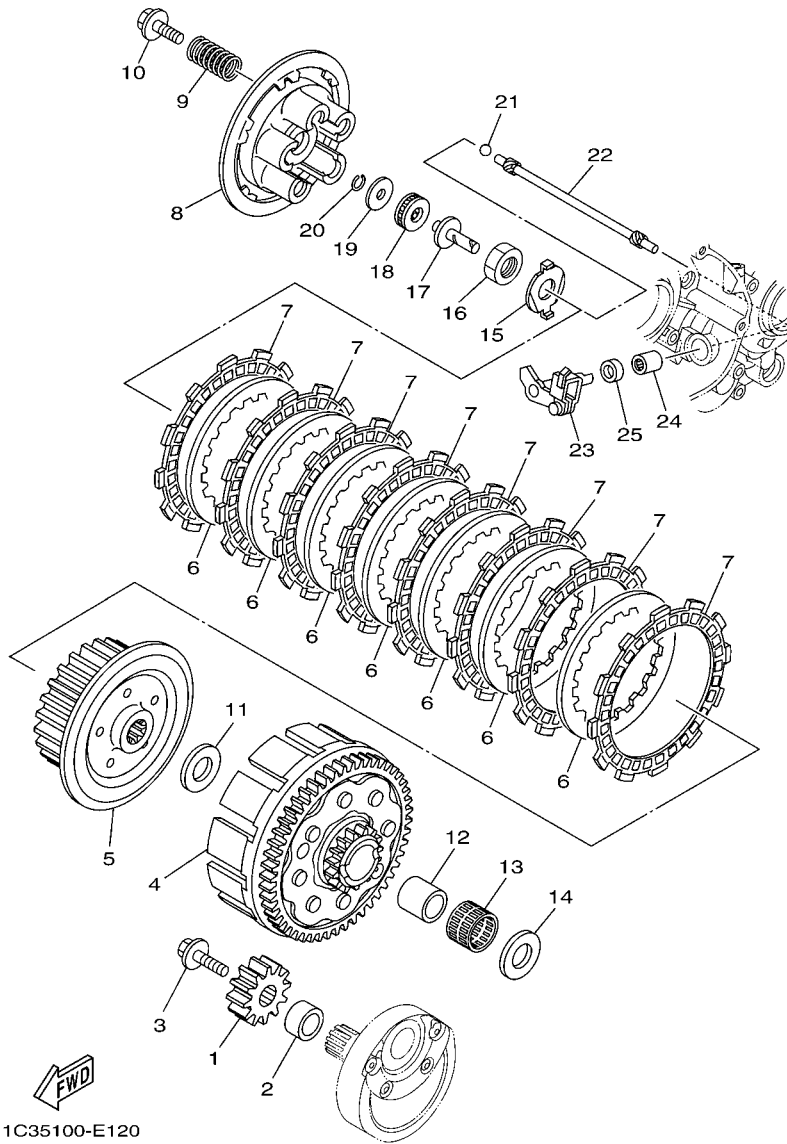

1C35100-E120

FIG. 12 CLUTCH

REF. NO.	PART NO.	DESCRIPTION	1C39	1C3A	1C3B	1C3C	REMARKS
1	1C3-16111-00	GEAR, PRIMARY DRIVE	1	1	1	1	
2	90387-172K2	COLLAR	1	1	1	1	
3	90105-08071	BOLT, FLANGE	1	1	1	1	
4	1C3-16150-00	PRIMARY DRIVEN GEAR COMP.	1	1	1	1	
5	5NY-16371-00	BOSS, CLUTCH	1	1	1	1	
6	3XJ-16324-01	PLATE, CLUTCH 1	7	7	7	7	
7	3XJ-16321-00	PLATE, FRICTION	8	8	8	8	
8	5HD-16351-00	PLATE, PRESSURE 1	1	1	1	1	
9	90501-23598	SPRING, COMPRESSION	5	5	5	5	
10	90159-06016	SCREW, WITH WASHER	5	5	5	5	
11	90201-20611	WASHER, PLATE	1	1	1	1	
12	1C3-16181-00	SPACER 1	1	1	1	1	
13	93310-22539	BEARING	1	1	1	1	
14	90201-20611	WASHER, PLATE	1	1	1	1	
15	90215-16289	WASHER, LOCK	1	1	1	1	
16	90170-16326	NUT	1	1	1	1	
17	5NL-16356-00	ROD, PUSH 1	1	1	1	1	
18	93340-21008	BEARING	1	1	1	1	
19	90201-080H1	WASHER, PLATE	1	1	1	1	
20	93440-07182	CIRCLIP	1	1	1	1	
21	93511-32027	BALL	1	1	1	1	
22	1C3-16357-10	ROD, PUSH 2	1	1	1	1	
23	1C3-16380-00	PUSH LEVER ASSY	1	1	1	1	
24	93315-11040	BEARING	1	1	1	1	
25	93102-10008	OIL SEAL	1	1	1	1	

FIG. 13 TRANSMISSION

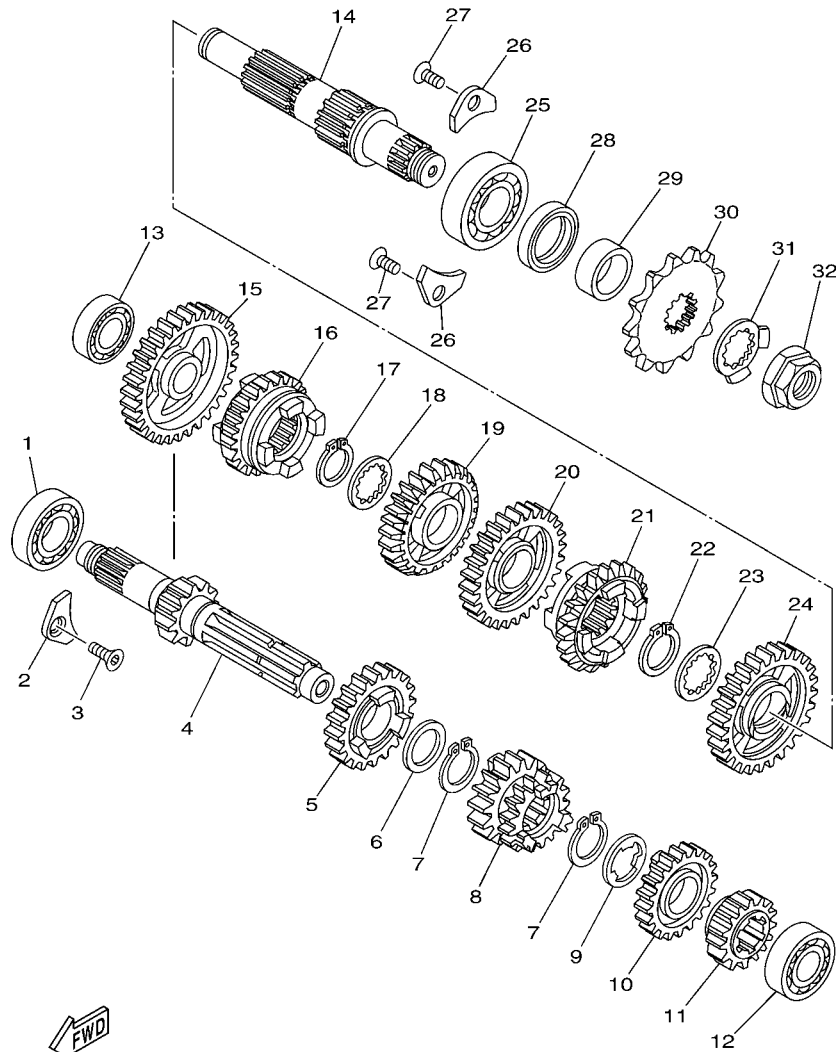

1C31100-D131

REF. NO.	PART NO.	DESCRIPTION	1C39	1C3A	1C3B	1C3C	REMARKS
1	93306-00442	BEARING	1	1	1	1	
2	4JT-15381-01	PLATE, BEARING COVER	1	1	1	1	
3	90149-06074	SCREW	1	1	1	1	
4	1C3-17411-10	AXLE, MAIN (13T)	1	1	1	1	
5	1C3-17161-10	GEAR, 6TH PINION (21T)	1	1	1	1	
6	90201-22555	WASHER, PLATE	1	1	1	1	
7	93410-22039	CIRCLIP	2	2	2	2	
8	1C3-17131-10	GEAR, 3RD PINION (17T/17T)	1	1	1	1	
9	90209-18135	WASHER	1	1	1	1	
10	1C3-17151-10	GEAR, 5TH PINION (20T)	1	1	1	1	
11	1C3-17121-10	GEAR, 2ND PINION (15T)	1	1	1	1	
12	93306-20351	BEARING	1	1	1	1	
13	93306-00326	BEARING	1	1	1	1	
14	1C3-17421-00	AXLE, DRIVE	1	1	1	1	
15	1C3-17211-10	GEAR, 1ST WHEEL (31T)	1	1	1	1	
16	1C3-17261-10	GEAR, 6TH WHEEL (23T)	1	1	1	1	
17	93410-22039	CIRCLIP	1	1	1	1	
18	90209-20008	WASHER	1	1	1	1	
19	1C3-17241-10	GEAR, 4TH WHEEL (23T)	1	1	1	1	
20	1C3-17231-20	GEAR, 3RD WHEEL (27T)	1	1	1	1	
21	1C3-17251-10	GEAR, 5TH WHEEL (24T)	1	1	1	1	
22	93410-26067	CIRCLIP	1	1	1	1	
23	90209-23012	WASHER	1	1	1	1	
24	1C3-17221-10	GEAR, 2ND WHEEL (29T)	1	1	1	1	
25	93306-20447	BEARING	1	1	1	1	
26	4JT-15381-01	PLATE, BEARING COVER	2	2	2	2	
27	90149-06074	SCREW	2	2	2	2	

FIG. 13 TRANSMISSION

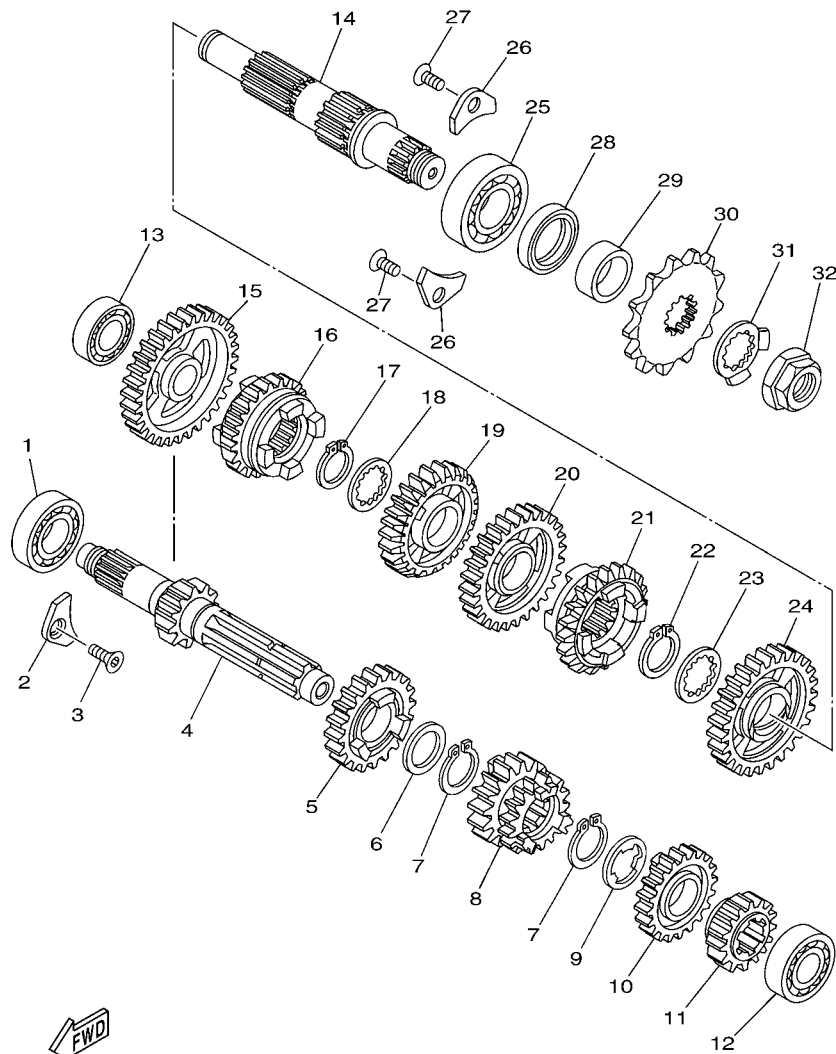

1C31100-D131

REF. NO.	PART NO.	DESCRIPTION	1C39	1C3A	1C3B	1C3C	REMARKS
28	93102-28012	OIL SEAL	1	1	1	1	
29	90387-22004	COLLAR	1	1	1	1	
30	9383B-13218	SPROCKET, DRIVE (13T)	1	1	1	1	
31	90215-20003	WASHER, LOCK	1	1	1	1	
32	90179-18001	NUT	1	1	1	1	
<hr style="border-top: 1px dashed black;"/>							
<hr style="border-top: 1px dashed black;"/>							
<hr style="border-top: 1px dashed black;"/>							
<hr style="border-top: 1px dashed black;"/>							
<hr style="border-top: 1px dashed black;"/>							
<hr style="border-top: 1px dashed black;"/>							
<hr style="border-top: 1px dashed black;"/>							
<hr style="border-top: 1px dashed black;"/>							

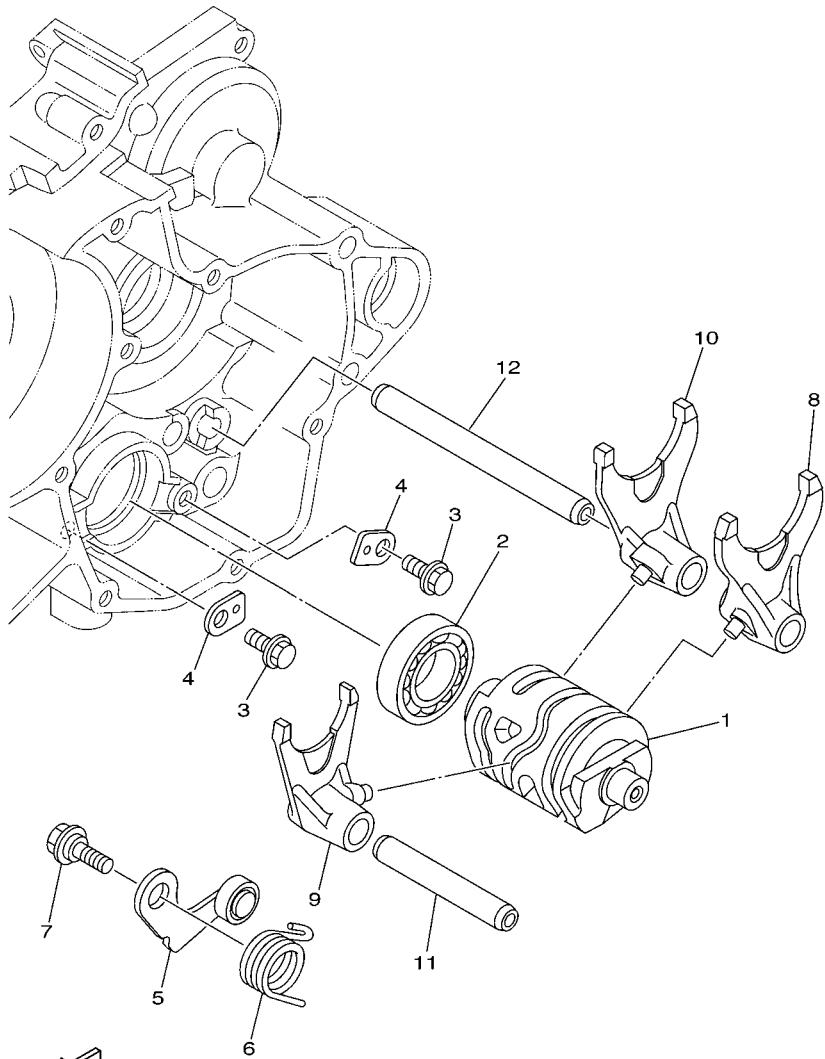



 1C31100-D140

FIG. 14 SHIFT CAM & FORK

REF. NO.	PART NO.	DESCRIPTION	1C39	1C3A	1C3B	1C3C	REMARKS
1	1C3-18541-00	CAM, SHIFT	1	1	1	1	
2	93306-90408	BEARING	1	1	1	1	
3	90105-06081	BOLT, FLANGE	2	2	2	2	
4	1C3-18562-00	PLATE, STOPPER 2	2	2	2	2	
5	1C3-18140-10	STOPPER LEVER ASSY	1	1	1	1	
6	90508-261B7	SPRING, TORSION	1	1	1	1	
7	90109-06193	BOLT	1	1	1	1	
8	1C3-18511-00	FORK, SHIFT 1	1	1	1	1	
9	1C3-18512-00	FORK, SHIFT 2	1	1	1	1	
10	1C3-18513-00	FORK, SHIFT 3	1	1	1	1	
11	3XV-18531-00	BAR, SHIFT FORK GUIDE 1	1	1	1	1	
12	4JG-18531-00	BAR, SHIFT FORK GUIDE 1	1	1	1	1	

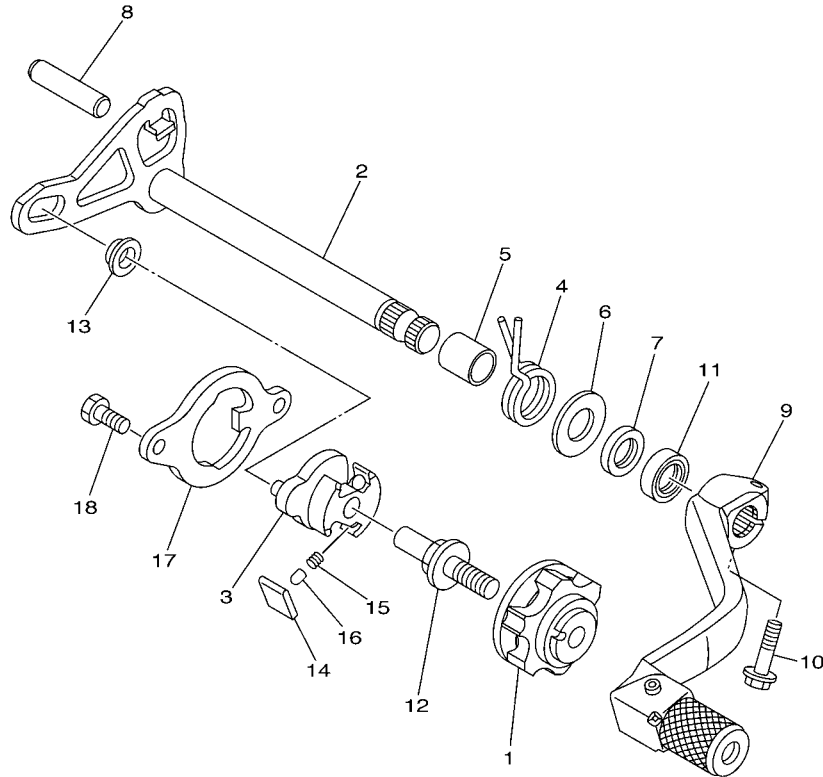
FIG. 15 SHIFT SHAFT



REF. NO.	PART NO.	DESCRIPTION	1C39	1C3A	1C3B	1C3C	REMARKS
1	1C3-18185-00	SEGMENT	1	1	1	1	
2	1C3-18101-00	SHIFT SHAFT ASSY	1	1	1	1	
3	5LP-18122-01	LEVER, SHIFT 2	1	1	1	1	
4	90508-29020	SPRING, TORSION	1	1	1	1	
5	90560-12280	SPACER	1	1	1	1	
6	90201-12020	WASHER, PLATE	1	1	1	1	
7	93104-12003	OIL SEAL	1	1	1	1	
8	93608-33002	PIN, DOWEL	1	1	1	1	
9	1C3-18110-00	SHIFT PEDAL ASSY	1	1	1	1	
10	95022-06020	BOLT, FLANGE	1	1	1	1	
11	93102-12224	OIL SEAL	1	1	1	1	
12	3XJ-18173-10	PIN, SHIFT	1	1	1	1	
13	3XJ-18178-00	ROLLER, SHIFT LEVER	1	1	1	1	
14	3XJ-18182-00	PAWL, SHIFTER	2	2	2	2	
15	90501-052G5	SPRING, COMPRESSION	2	2	2	2	
16	3XJ-18184-00	PIN, PAWL	2	2	2	2	
17	1C3-18172-00	GUIDE, SHIFT	1	1	1	1	
18	90101-06041	BOLT	2	2	2	2	

1C31100-D150

FIG. 16 FRAME

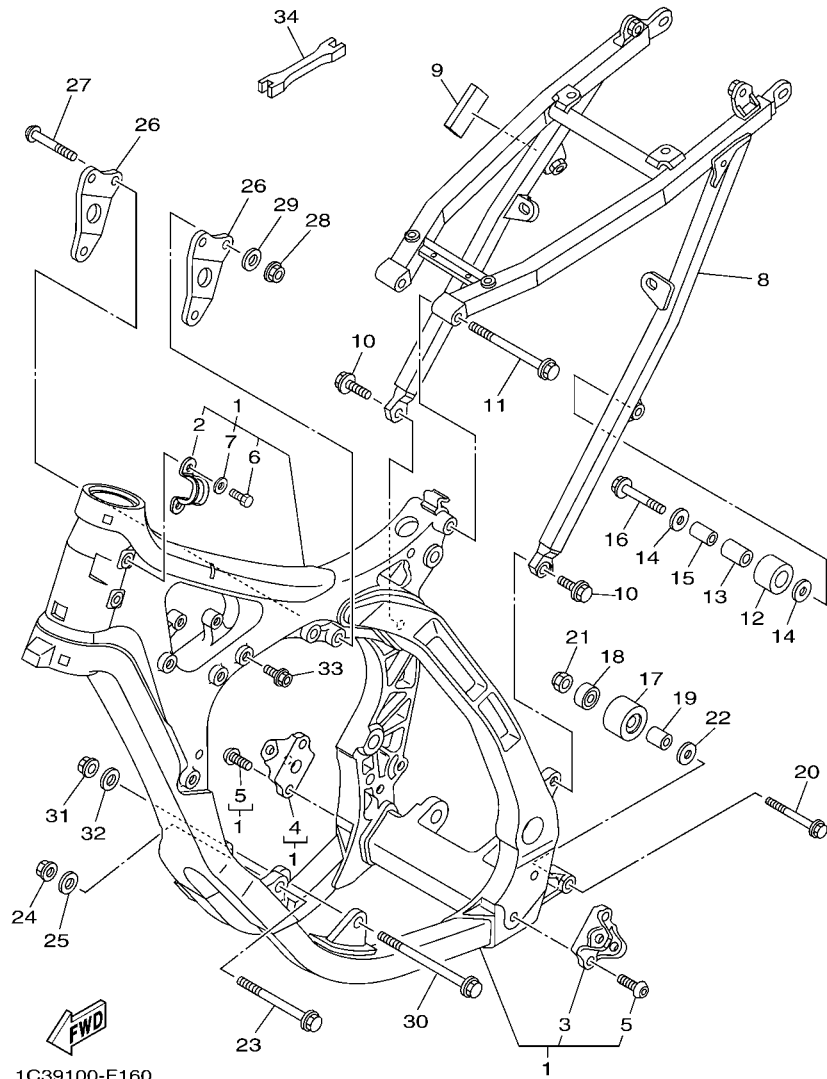

REF. NO.	PART NO.	DESCRIPTION	1C39	1C3A	1C3B	1C3C	REMARKS
1	1C3-21101-50	FRONT FRAME COMP.	1	1	1	1	
2	1C3-21336-00	.CLAMP, WIRE HARNESS 2	1	1	1	1	
3	1C3-21447-10	.BRACKET, FOOTREST	1	1	1	1	
4	1C3-21448-10	.BRACKET, FOOTREST	1	1	1	1	
5	90149-10031	.SCREW	4	4	4	4	
6	97004-05012	.BOLT	2	2	2	2	
7	92904-05600	.WASHER	2	2	2	2	
8	1C3-21190-90	REAR FRAME COMP.	1	1	1	1	
9	5GJ-21717-00	DAMPER	1	1	1	1	
10	90105-08085	BOLT, FLANGE	2	2	2	2	
11	90105-08132	BOLT, FLANGE	1	1	1	1	
12	30X-22178-00	TENSIONER	1	1	1	1	
13	4V4-22184-00	BUSH	1	1	1	1	
14	90201-08045	WASHER, PLATE	2	2	2	2	
15	90387-08041	COLLAR	1	1	1	1	
16	95022-08040	BOLT, FLANGE	1	1	1	1	
17	3JD-22178-20	TENSIONER	1	1	1	1	
18	93300-60839	BEARING	1	1	1	1	
19	90387-086N4	COLLAR	1	1	1	1	
20	90105-08133	BOLT, FLANGE	1	1	1	1	
21	90185-08009	NUT, SELF-LOCKING	1	1	1	1	
22	90201-08043	WASHER, PLATE	1	1	1	1	
23	90105-10175	BOLT, FLANGE	1	1	1	1	
24	90179-10658	NUT	1	1	1	1	
25	92902-10200	WASHER	1	1	1	1	
26	1C3-21425-00	BRACKET, REAR UPPER 1	2	2	2	2	
27	90111-08028	BOLT,HEX. SOCKET BUTTON	3	3	3	3	

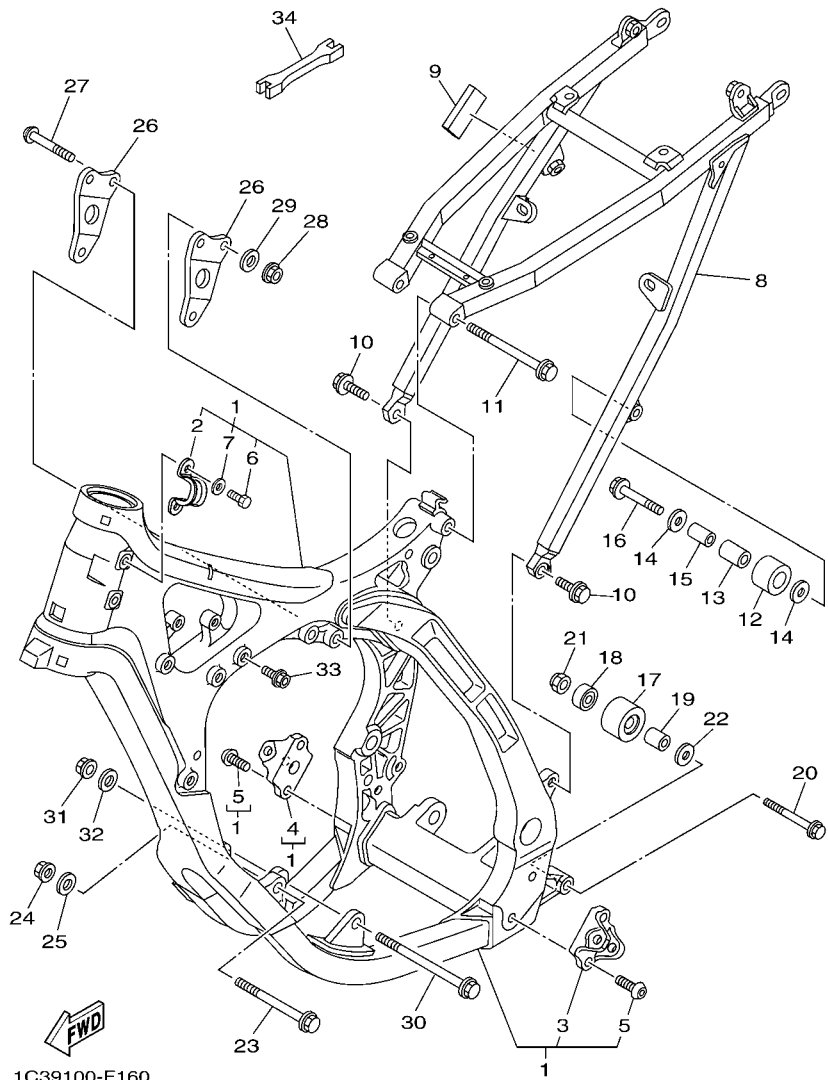

1C39100-F160

FIG. 16 FRAME

REF. NO.	PART NO.	DESCRIPTION	1C39	1C3A	1C3B	1C3C	REMARKS
28	90179-08674	NUT	3	3	3	3	
29	90201-08055	WASHER, PLATE	3	3	3	3	
30	90105-10176	BOLT, FLANGE	1	1	1	1	
31	90179-10658	NUT	1	1	1	1	
32	92902-10200	WASHER	1	1	1	1	
33	1C3-21244-10	NUT	2	2	2	2	
34	5ET-28166-10	WRENCH, HEXAGON	1	1	1	1	

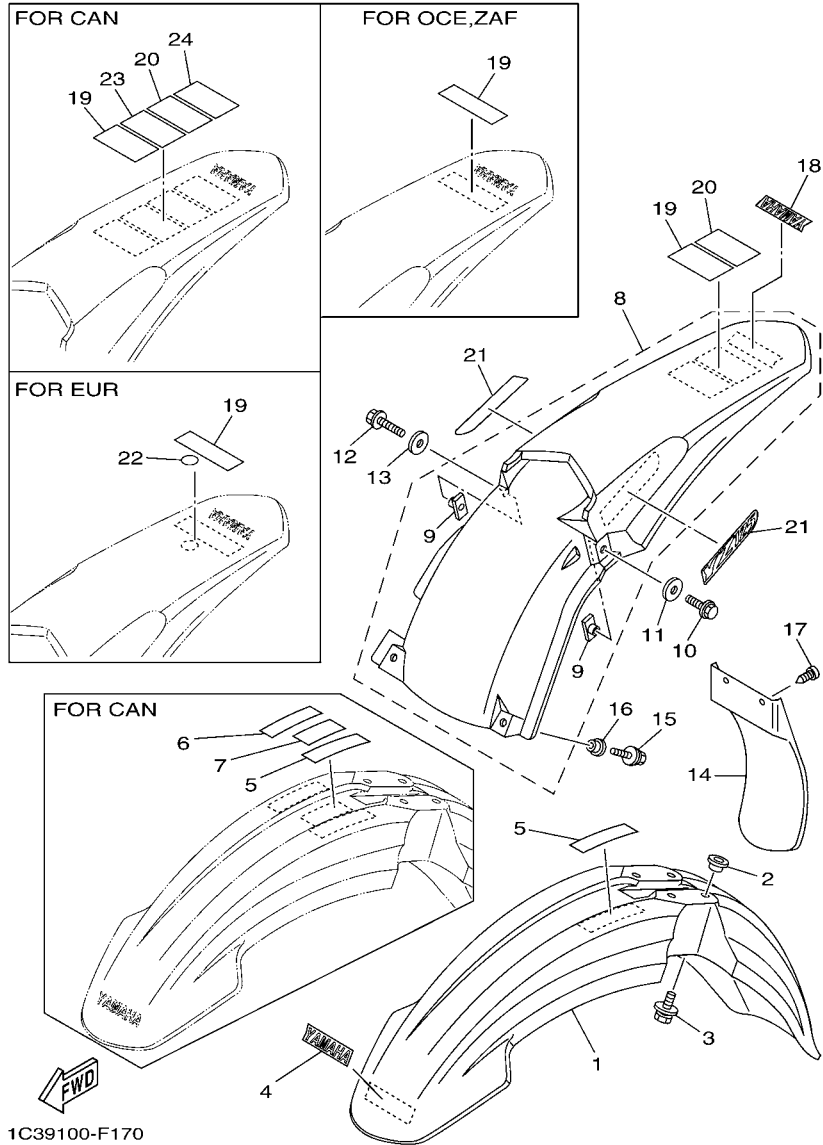

FIG. 17 FENDER

REF. NO.	PART NO.	DESCRIPTION	1C39	1C3A	1C3B	1C3C	REMARKS
1	1C3-21511-51	FENDER, FRONT	1	1	1	1	
2	90387-06090	COLLAR	4	4	4	4	
3	90119-06147	BOLT, WITH WASHER	4	4	4	4	
4	4ES-2153E-01	EMBLEM, YAMAHA	1	1	1	1	
5	N/A						
6	N/A						
7	N/A						
8	5XE-21610-10	REAR FENDER COMP.	1	1	1	1	
9	5XE-21635-10	.NUT, REAR FENDER	2	2	2	2	
10	90105-06099	BOLT, FLANGE	1	1	1	1	
11	90201-06032	WASHER, PLATE	1	1	1	1	
12	90105-06101	BOLT, FLANGE	1	1	1	1	
13	90201-06033	WASHER, PLATE	1	1	1	1	
14	5UN-21642-10	GUARD, FLAP	1	1	1	1	
15	90119-06149	BOLT, WITH WASHER	2	2	2	2	
16	90387-06009	COLLAR	2	2	2	2	
17	97702-60016	SCREW, TAPPING	2	2	2	2	
18	4ES-2153E-01	EMBLEM, YAMAHA	1	1	1	1	
19	5PA-21568-00	LABEL, CAUTION				1	
20	N/A						
21	1C3-2163G-00	EMBLEM 1	2	2	2	2	
22	N/A						
23	N/A						

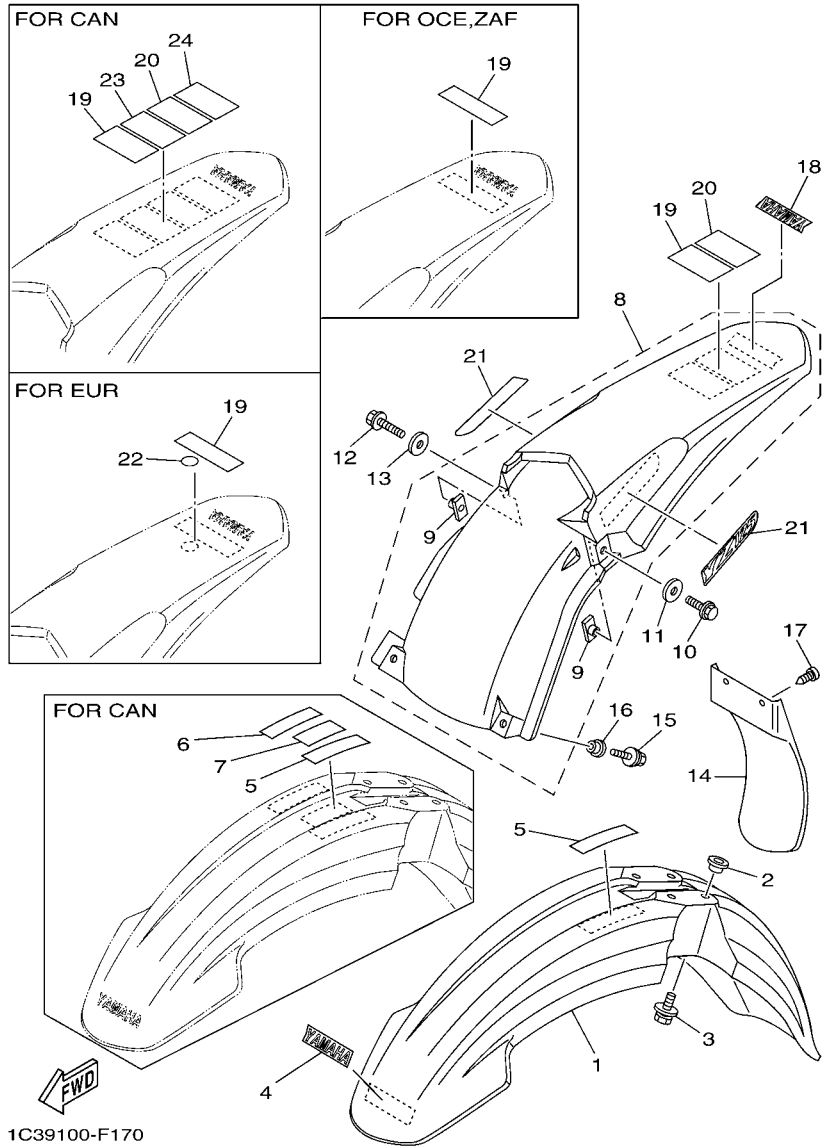

FIG. 17 FENDER

REF. NO.	PART NO.	DESCRIPTION	1C39	1C3A	1C3B	1C3C	REMARKS
24	N/A						

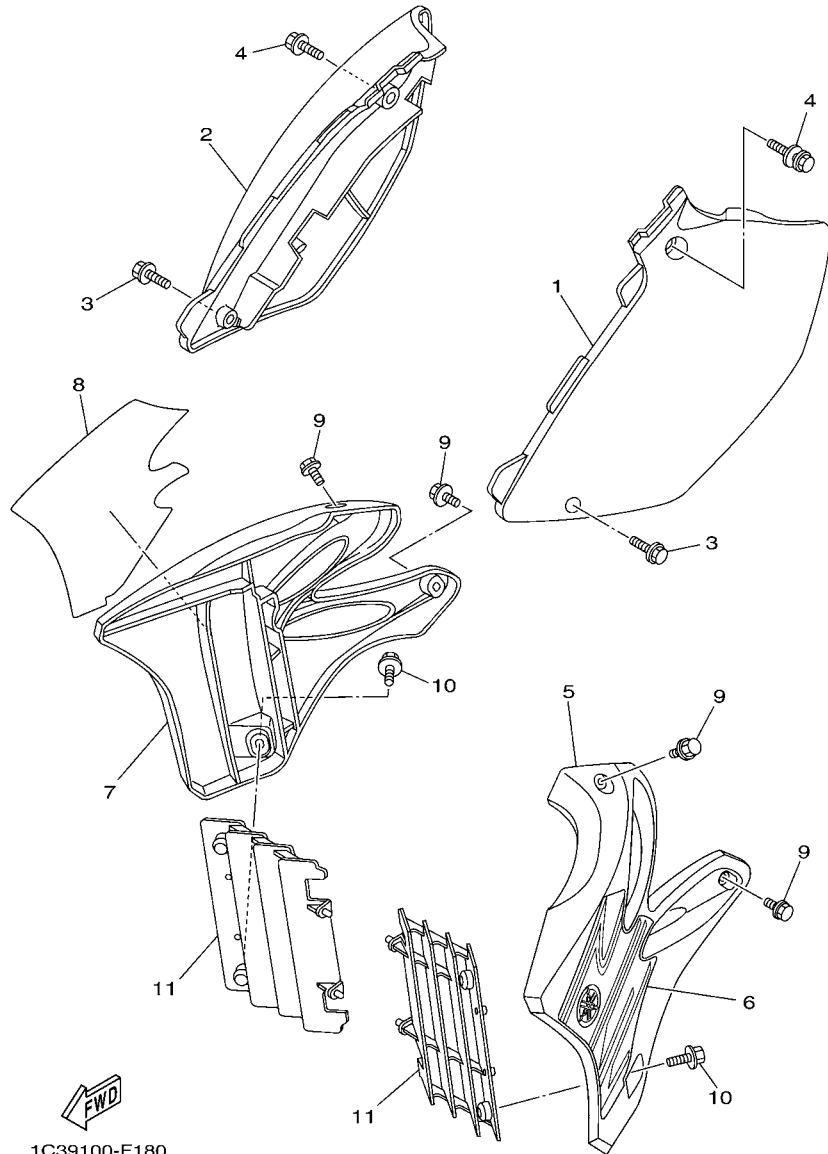
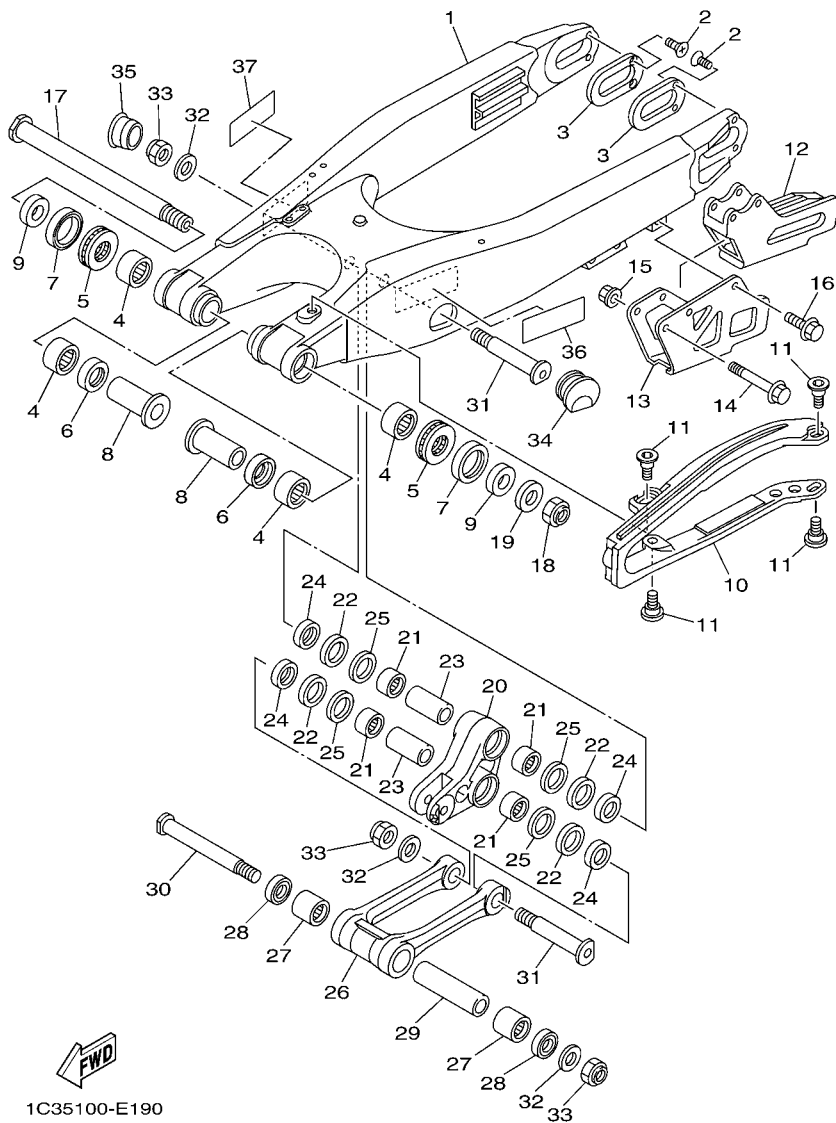

FIG. 18 SIDE COVER

REF. NO.	PART NO.	DESCRIPTION	1C39	1C3A	1C3B	1C3C	REMARKS
1	5NY-21711-00	COVER, SIDE 1	1	1	1	1	
2	1C3-21721-50	COVER, SIDE 2				1	
3	90105-06103	BOLT, FLANGE	2	2	2	2	
4	90119-08095	BOLT, WITH WASHER	2	2	2	2	
5	5XE-21730-00	SIDE COVER ASSY 3	1	1	1	1	
6	1C3-2173E-20	GRAPHIC 1	1	1	1	1	
7	5XE-21740-00	SIDE COVER ASSY 4	1	1	1	1	
8	1C3-2173F-20	GRAPHIC 2	1	1	1	1	
9	90105-06064	BOLT, FLANGE	4	4	4	4	
10	90159-06021	SCREW, WITH WASHER	2	2	2	2	
11	5NL-2172A-20	PANEL 1	2	2	2	2	



1C35100-E190

FIG. 19 REAR ARM

REF. NO.	PART NO.	DESCRIPTION	1C39	1C3A	1C3B	1C3C	REMARKS
1	1C3-22110-50	REAR ARM COMP.	1	1	1	1	
2	90151-04003	SCREW, COUNTERSUNK	4	4	4	4	
3	1C3-22355-00	PATCH	2	2	2	2	
4	93317-22262	BEARING	4	4	4	4	
5	93342-22217	BEARING	2	2	2	2	
6	93106-22002	OIL SEAL	2	2	2	2	
7	93109-28043	OIL SEAL	2	2	2	2	
8	90387-18010	COLLAR	2	2	2	2	
9	90387-18012	COLLAR	2	2	2	2	
10	1C3-22151-00	SEAL, GUARD	1	1	1	1	
11	1C3-22969-90	SCREW, 1	4	4	4	4	
12	1C3-22199-10	SUPPORT, CHAIN	1	1	1	1	
13	1C3-22128-00	COVER, THRUST 1	1	1	1	1	
14	90105-06104	BOLT, FLANGE	2	2	2	2	
15	90179-06028	NUT	2	2	2	2	
16	90105-06105	BOLT, FLANGE	1	1	1	1	
17	1C3-22141-10	SHAFT, PIVOT	1	1	1	1	
18	90185-16002	NUT, SELF-LOCKING	1	1	1	1	
19	90201-16018	WASHER, PLATE	1	1	1	1	
20	1C3-2217A-00	ARM, RELAY	1	1	1	1	
21	93315-32166	BEARING	4	4	4	4	
22	93109-25001	OIL SEAL	4	4	4	4	
23	90387-16010	COLLAR	2	2	2	2	
24	90209-16011	WASHER	4	4	4	4	
25	90201-21014	WASHER, PLATE	4	4	4	4	
26	1C3-2217F-50	ROD, CONNECTING 1	1	1	1	1	
27	93315-32166	BEARING	2	2	2	2	

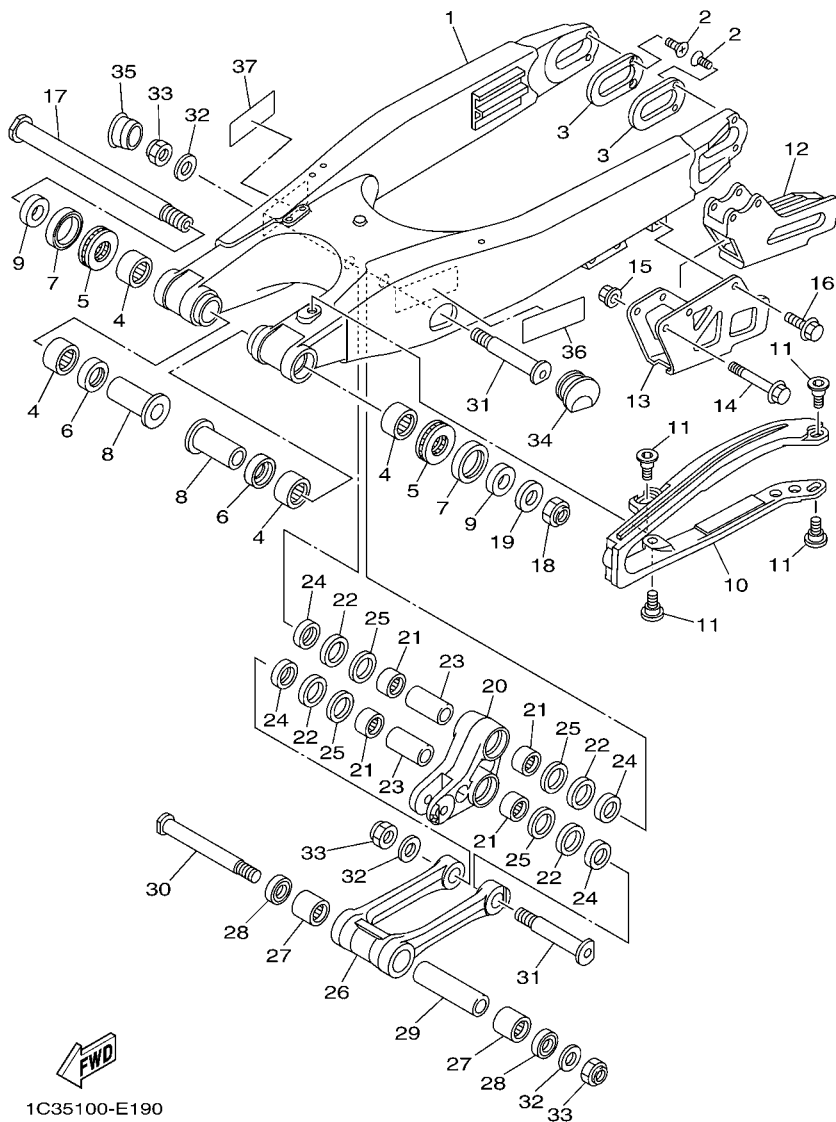

1C35100-E190

FIG. 19 REAR ARM

REF. NO.	PART NO.	DESCRIPTION	1C39	1C3A	1C3B	1C3C	REMARKS
28	93109-21001	OIL SEAL	2	2	2	2	
29	90387-14005	COLLAR	1	1	1	1	
30	1C3-22121-00	SHAFT 1	1	1	1	1	
31	1C3-22122-00	SHAFT 2	2	2	2	2	
32	90201-14020	WASHER, PLATE	3	3	3	3	
33	90185-14010	NUT, SELF-LOCKING	3	3	3	3	
34	1C3-2135F-00	COVER	1	1	1	1	
35	1C3-2139R-00	COVER 2	1	1	1	1	
36	3RV-21668-A0	LABEL, TIRE	1	1		1	
37	N/A						

FIG. 20 REAR SUSPENSION

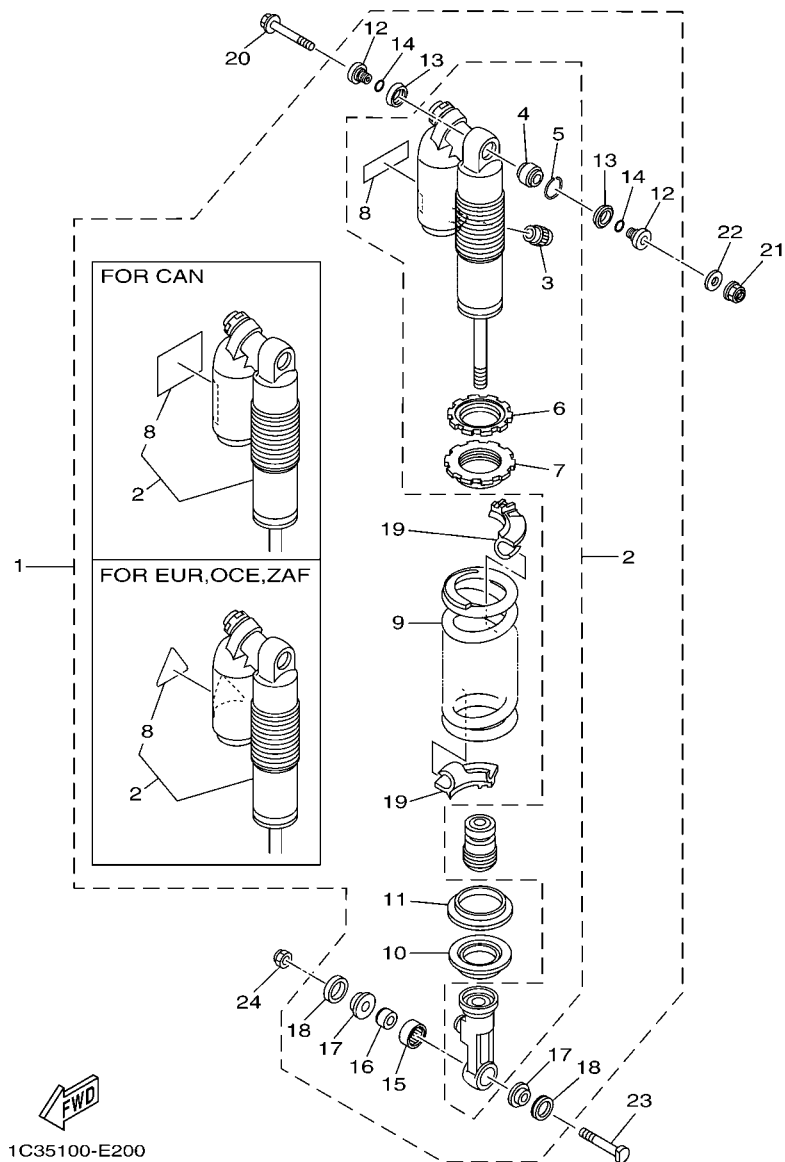

REF. NO.	PART NO.	DESCRIPTION	1C39	1C3A	1C3B	1C3C	REMARKS
1	1C3-22200-D0	SHOCK ABSORBER ASSY, REAR				1	
2	1C3-22201-A0	.DAMPER SUB ASSY	1		1	1	
	1C3-22201-B0	.DAMPER SUB ASSY		1			
3	509-23184-L0	..CAP, AIR VALVE	1	1	1	1	
4	4JX-22226-00	..BUSH, SHOCK ABSORBER LOWER	1	1	1	1	
5	5DH-23183-00	..CIRCLIP	1	1	1	1	
6	3SP-22234-00	..GUIDE, SPRING 3	1	1	1	1	
7	1C3-22213-L0	..SEAT, SPRING UPPER	1	1	1	1	
8	4AA-22259-40	..LABEL, WARNING				1	
9	1C3-22212-10	.SPRING (K=46N/MM)	1	1	1	1	
10	1C3-22214-50	.GUIDE, SPRING 1	1	1	1	1	
11	5MV-22224-00	.GUIDE, SPRING 2	1	1	1	1	
12	1C3-22253-50	.COLLAR, DISTANCE	2	2	2	2	
13	3JE-22475-00	.SEAL, DUST	2	2	2	2	
14	4EW-22474-00	.SEAL, RING	2	2	2	2	
15	5UN-22176-00	.BEARING	1	1	1	1	
16	5MV-22184-00	.BUSH	1	1	1	1	
17	1C3-22253-L0	.COLLAR, DISTANCE	2	2	2	2	
18	5NY-22475-00	.SEAL, DUST	2	2	2	2	
19	1C3-22565-00	.SPRING SEAT	2	2	2	2	

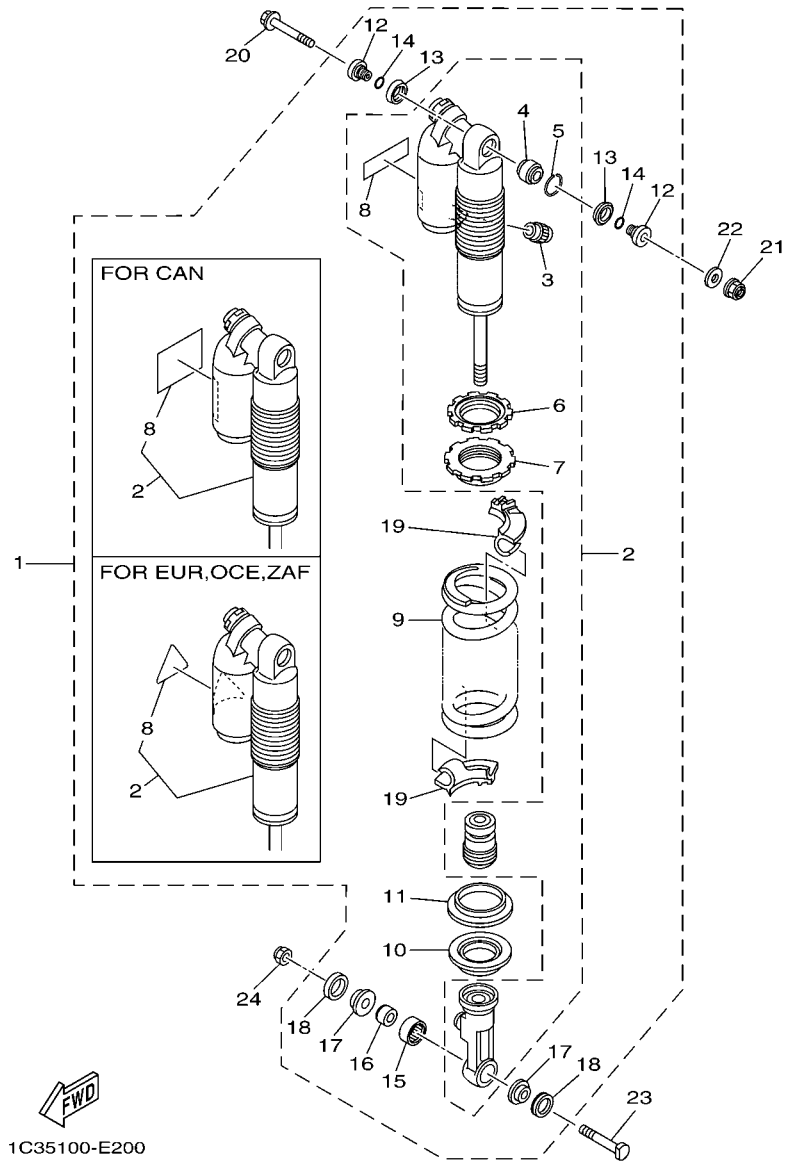
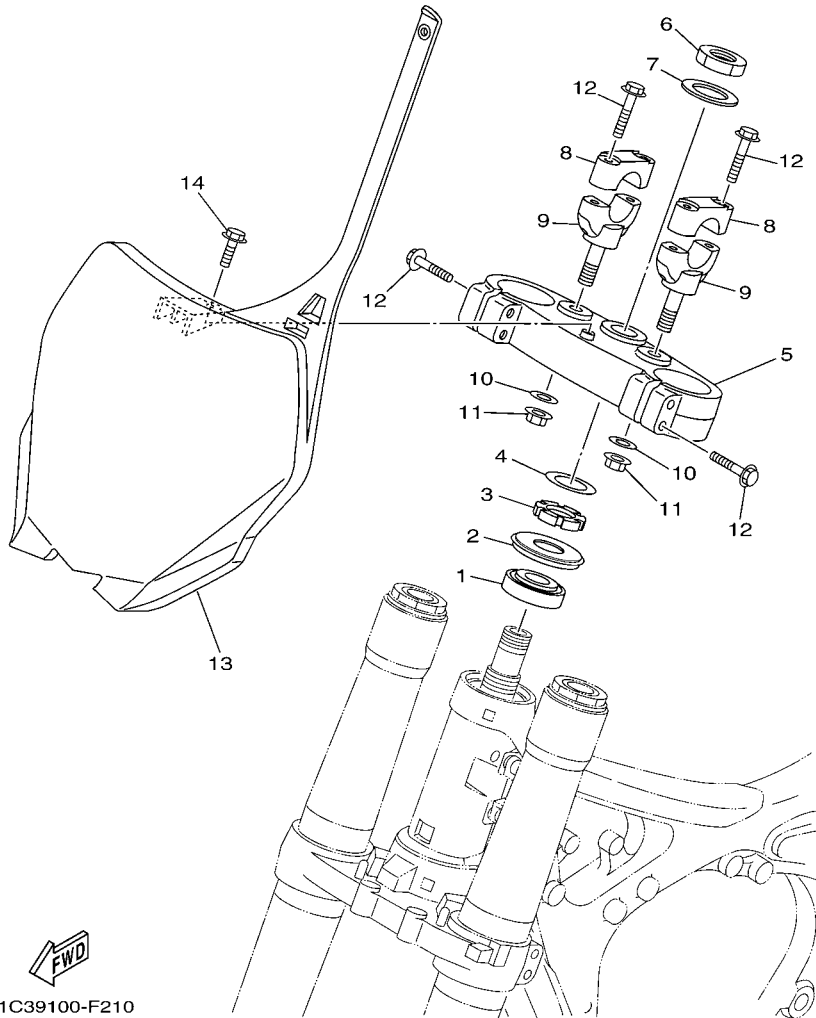

FIG. 20 REAR SUSPENSION

REF. NO.	PART NO.	DESCRIPTION	1C39	1C3A	1C3B	1C3C	REMARKS
20	5XE-22242-00	BOLT 2	1	1	1	1	
21	95602-10200	NUT, U FLANGE	1	1	1	1	
22	92902-10200	WASHER	1	1	1	1	
23	5NY-22241-00	BOLT 1	1	1	1	1	
24	90185-10012	NUT, SELF-LOCKING	1	1	1	1	

FIG. 21 STEERING



1C39100-F210

REF. NO.	PART NO.	DESCRIPTION	1C39	1C3A	1C3B	1C3C	REMARKS
1	93332-00068	BEARING	1	1	1	1	
2	4EW-23416-00	COVER, BALL RACE 2	1	1	1	1	
3	90179-28003	NUT	1	1	1	1	
4	90201-286K9	WASHER, PLATE	1	1	1	1	
5	1C3-23435-50	CROWN, HANDLE	1	1	1	1	
6	90170-24003	NUT	1	1	1	1	
7	90201-24016	WASHER, PLATE	1	1	1	1	
8	5XC-23441-90	HOLDER, HANDLE UPPER	2	2	2	2	
9	5XC-23442-90	HOLDER, HANDLE LOWER	2	2	2	2	
10	90201-12028	WASHER, PLATE	2	2	2	2	
11	95602-12200	NUT, SELF-LOCKING	2	2	2	2	
12	90105-08134	BOLT, FLANGE	8	8	8	8	
13	1C3-23485-61	PLATE, NUMBER	1	1	1	1	
14	90119-06151	BOLT, WITH WASHER	1	1	1	1	

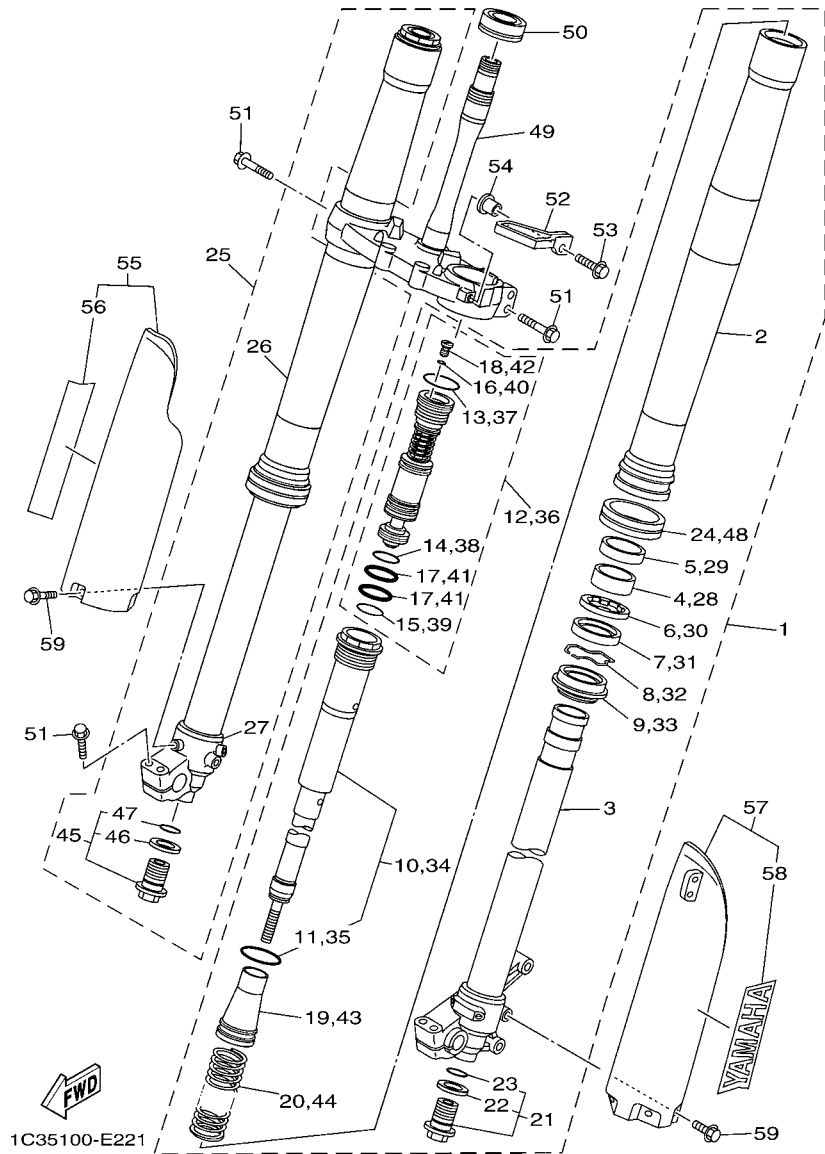

FIG. 22 FRONT FORK

REF. NO.	PART NO.	DESCRIPTION	1C39	1C3A	1C3B	1C3C	REMARKS
1	1C3-23102-A0	FRONT FORK ASSY (L.H)	1		1	1	
2	1C3-23136-N0	.TUBE, OUTER (RIGHT)	1	1	1	1	
3	5XC-23120-L0	.INNER TUBE COMP.2	1	1	1	1	
4	5XE-23171-L0	.PISTON, FRONT FORK	1	1	1	1	
5	5XE-23125-L0	.METAL, SLIDE 1	1	1	1	1	
6	5XE-23146-L0	.WASHER, OIL SEAL	1	1	1	1	
7	1C3-23145-M0	.OIL SEAL	1	1	1	1	
8	5XE-23153-L0	.RING, SNAP	1	1	1	1	
9	5XE-23144-L0	.SEAL, DUST	1	1	1	1	
10	1C3-23170-R0	.CYLINDER COMP., FRONT FORK	1		1	1	
11	1C3-23147-L0	..O-RING	1	1	1	1	
12	1C3-2316A-N0	.VALVE COMP.	1		1	1	
13	1C3-23188-L0	..O-RING	1	1	1	1	
14	1C3-23188-N0	..O-RING	1	1	1	1	
15	1C3-23188-P0	..O-RING	1	1	1	1	
16	1C3-23188-R0	..O-RING	1	1	1	1	
17	1AE-23147-00	..O-RING	2	2	2	2	
18	1C3-23190-L0	..AIR VALVE COMP.	1	1	1	1	
19	1C3-23142-L0	.SEAT, SPRING UPPER	1	1	1	1	
20	1C3-23141-N1	.SPRING, FRONT FORK(K=4.0N/MM)	1	1	1	1	
21	1C3-23111-L1	.BOLT, CAP	1	1	1	1	
22	2HH-23158-L0	..GASKET	1	1	1	1	
23	276-23114-00	..GASKET	1	1	1	1	
24	1C3-2314F-M0	.PROTECTOR GUIDE COMP., 1	1	1	1	1	

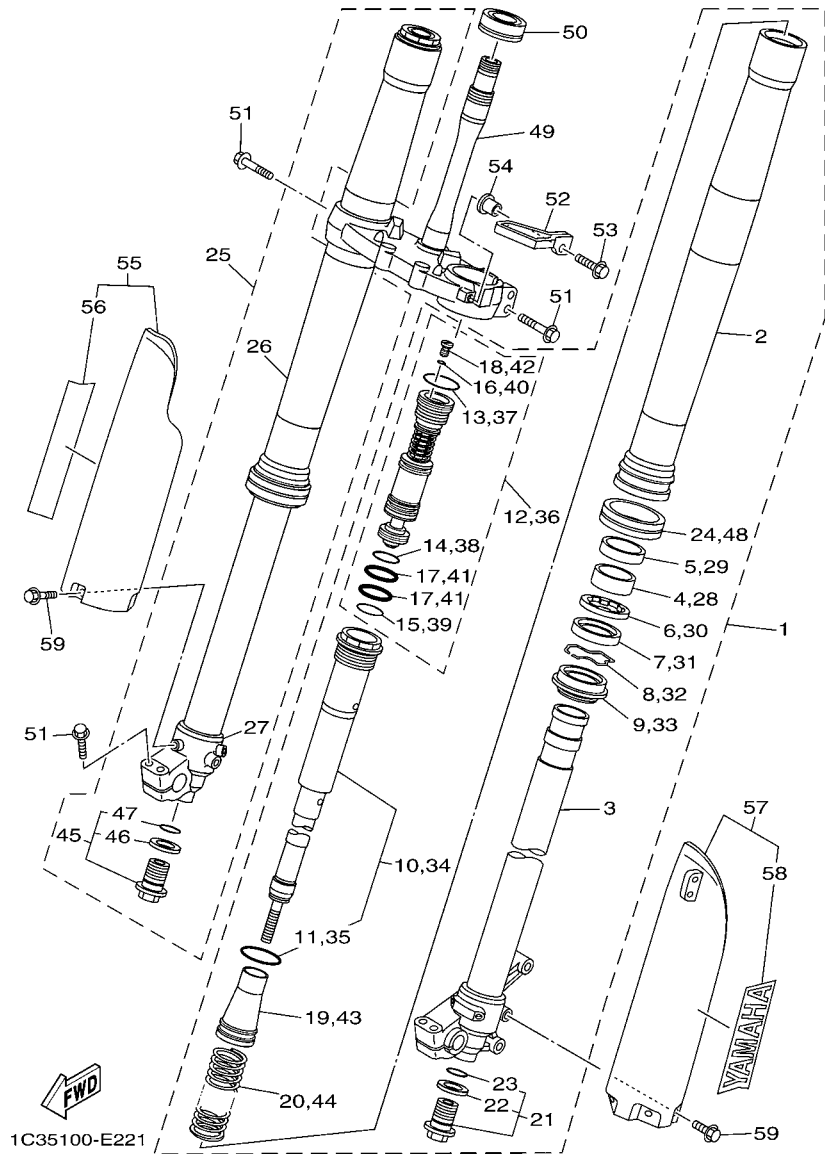
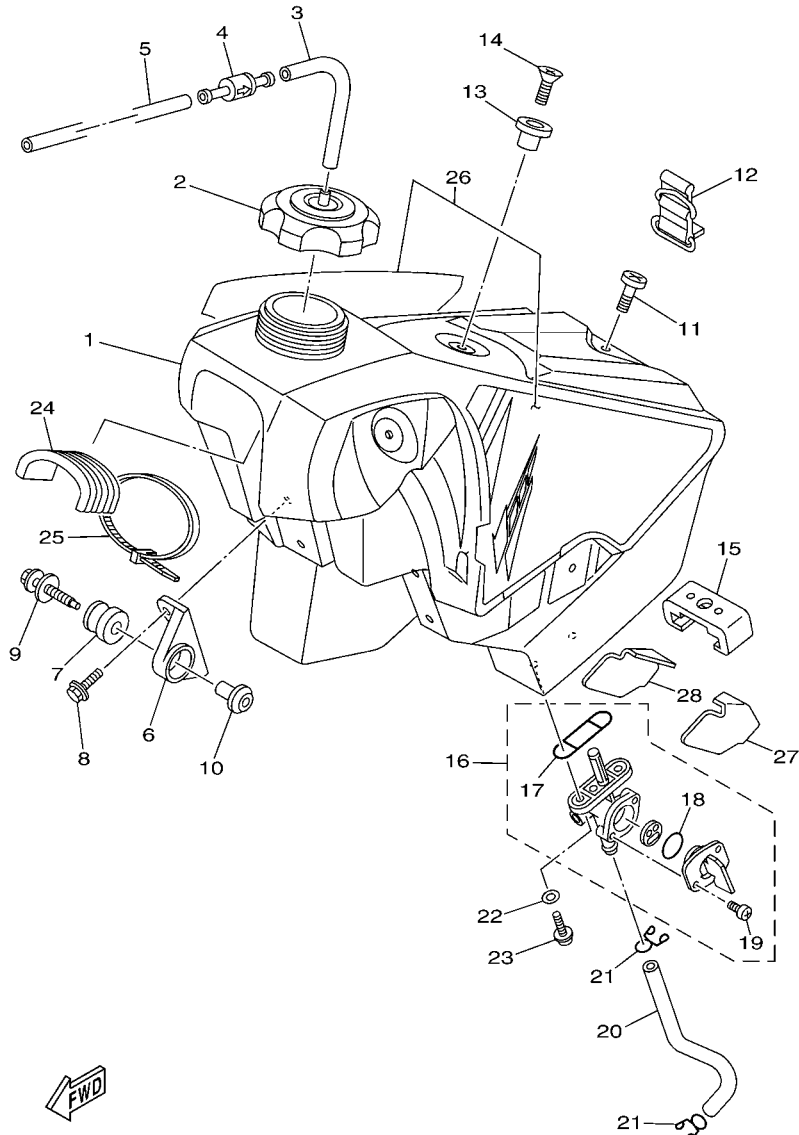

FIG. 22 FRONT FORK

REF. NO.	PART NO.	DESCRIPTION	1C39	1C3A	1C3B	1C3C	REMARKS
25	1C3-23103-A0	FRONT FORK ASSY (R.H)	1		1	1	
26	1C3-23136-N0	.TUBE, OUTER (RIGHT)	1	1	1	1	
27	5XC-23110-L0	.INNER TUBE COMP.1	1	1	1	1	
28	5XE-23171-L0	.PISTON, FRONT FORK	1	1	1	1	
29	5XE-23125-L0	.METAL, SLIDE 1	1	1	1	1	
30	5XE-23146-L0	.WASHER, OIL SEAL	1	1	1	1	
31	1C3-23145-M0	.OIL SEAL	1	1	1	1	
32	5XE-23153-L0	.RING, SNAP	1	1	1	1	
33	5XE-23144-L0	.SEAL, DUST	1	1	1	1	
34	1C3-23170-R0	.CYLINDER COMP., FRONT FORK	1		1	1	
35	1C3-23147-L0	..O-RING	1	1	1	1	
36	1C3-2316A-N0	.VALVE COMP.	1		1	1	
37	1C3-23188-L0	..O-RING	1	1	1	1	
38	1C3-23188-N0	..O-RING	1	1	1	1	
39	1C3-23188-P0	..O-RING	1	1	1	1	
40	1C3-23188-R0	..O-RING	1	1	1	1	
41	1AE-23147-00	..O-RING	2	2	2	2	
42	1C3-23190-L0	..AIR VALVE COMP.	1	1	1	1	
43	1C3-23142-L0	.SEAT, SPRING UPPER	1	1	1	1	
44	1C3-23141-N1	.SPRING, FRONT FORK(K=4.0N/MM)	1	1	1	1	
45	1C3-23111-L1	.BOLT, CAP	1	1	1	1	
46	2HH-23158-L0	..GASKET	1	1	1	1	
47	276-23114-00	..GASKET	1	1	1	1	
48	1C3-2314F-M0	.PROTECTOR GUIDE COMP., 1	1	1	1	1	

FIG. 23 FUEL TANK



1C39100-F230

REF. NO.	PART NO.	DESCRIPTION	1C39	1C3A	1C3B	1C3C	REMARKS
1	1C3-24110-90	FUEL TANK COMP.	1	1	1	1	
2	5NY-24610-00	CAP ASSY	1	1	1	1	
3	90445-09220	HOSE (L30)	1	1	1	1	
4	3XJ-24380-00	PIPE JOINT ASSY	1	1	1	1	
5	90445-09251	HOSE (L350)	1	1	1	1	
6	5XE-24144-00	HOLDER, DAMPER	2	2	2	2	
7	90480-18549	GROMMET	2	2	2	2	
8	90105-06107	BOLT, FLANGE	4	4	4	4	
9	5XE-24176-10	BOLT 1	2	2	2	2	
10	5NY-24186-00	WASHER, SPECIAL	2	2	2	2	
11	98902-06025	SCREW, BIND	1	1	1	1	
12	3SP-24173-00	BAND, TANK FITTING 1	1	1	1	1	
13	4EW-2412F-00	BRACKET, SEAT	1	1	1	1	
14	98702-06025	SCREW, FLAT HEAD	1	1	1	1	
15	1C3-24181-00	DAMPER, LOCATING 1	1	1	1	1	
16	3JD-24500-10	FUEL COCK ASSY 1	1	1	1	1	
17	4X8-24512-00	.O-RING	1	1	1	1	
18	3AJ-24534-01	.SEAL, COCK	1	1	1	1	
19	98507-03008	.SCREW, PAN HEAD	2	2	2	2	
20	90445-111J0	HOSE (L145)	1	1	1	1	
21	90467-100A1	CLIP	2	2	2	2	
22	90202-05193	WASHER, PLATE	2	2	2	2	
23	90149-06108	SCREW	2	2	2	2	
24	1C3-24182-00	DAMPER, LOCATING 2	1	1	1	1	
25	90465-13275	CLAMP	1	1	1	1	
26	1C3-24240-20	GRAPHIC SET	1	1	1	1	
27	1C3-24183-00	DAMPER, LOCATING 3	1	1	1	1	

FIG. 23 FUEL TANK

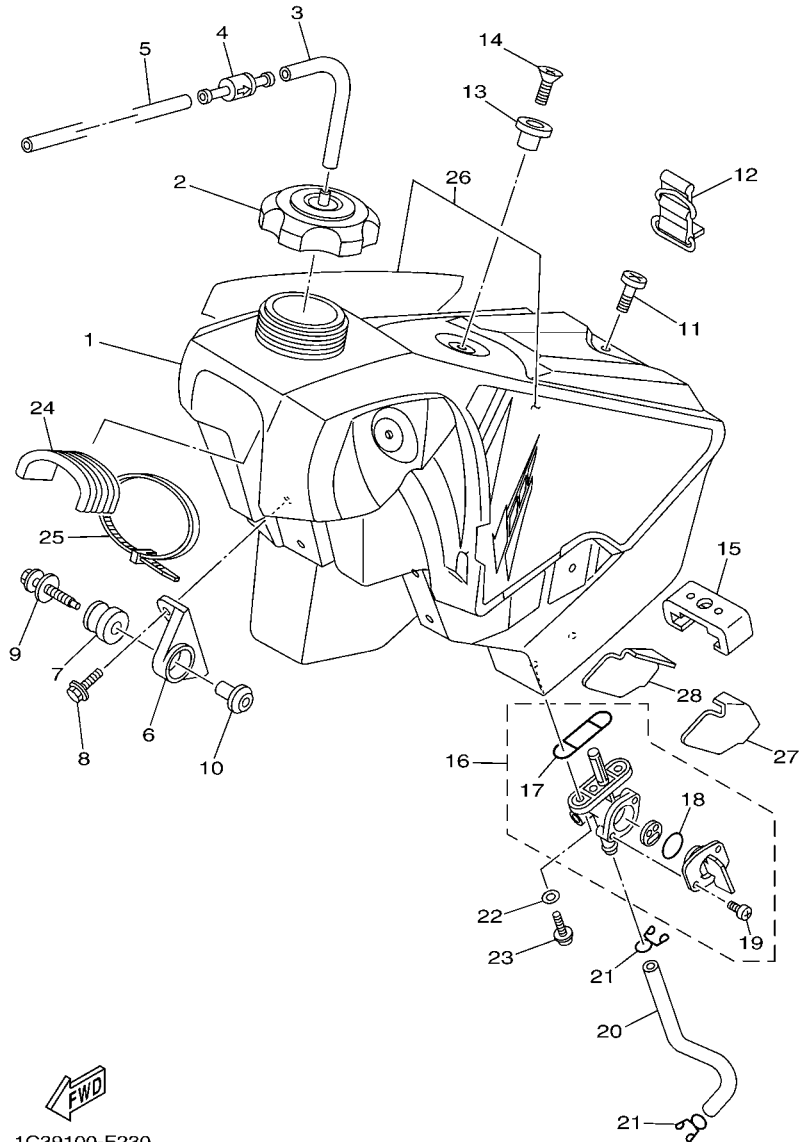

1C39100-F230

REF. NO.	PART NO.	DESCRIPTION	1C39	1C3A	1C3B	1C3C	REMARKS
28	1C3-24184-00	DAMPER, LOCATING 4	1	1	1	1	

FIG. 24 SEAT

REF. NO.	PART NO.	DESCRIPTION	1C39	1C3A	1C3B	1C3C	REMARKS
1	1C3-24770-51	SEMI-DOUBLE SEAT ASSY	1	1	1	1	
2	1C3-2470F-50	.SEAT COVER COMP.	1	1	1	1	
3	5NY-24728-10	.BRACKET, SEAT	2	2	2	2	
4	97002-06012	.BOLT	4	4	4	4	
5	92902-06100	.WASHER, SPRING	4	4	4	4	

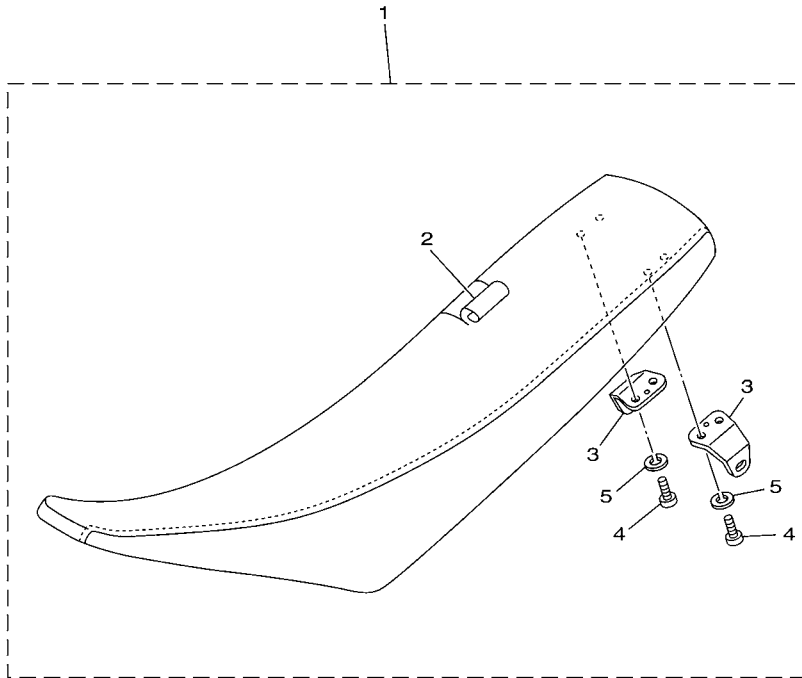

5NY1100-A241

FIG. 25 FRONT WHEEL

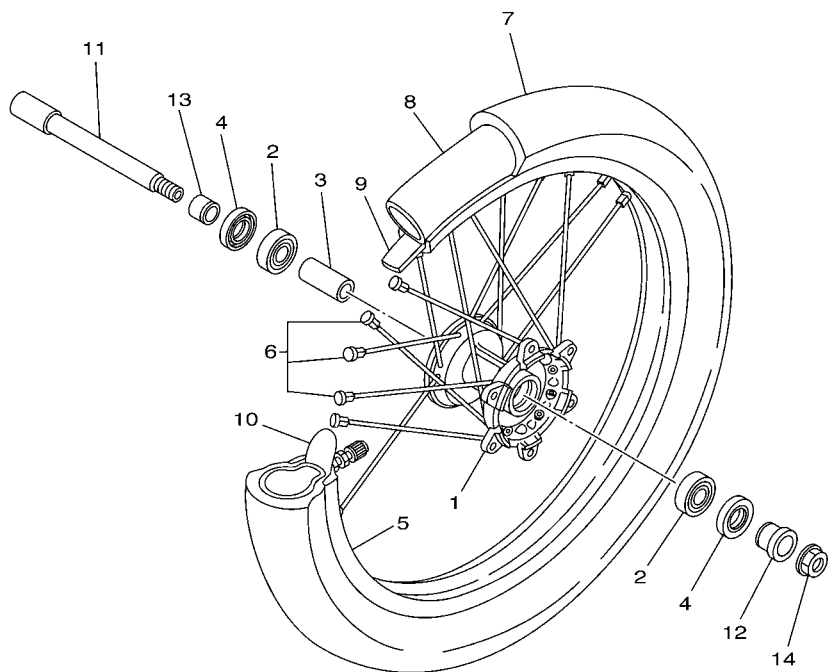

REF. NO.	PART NO.	DESCRIPTION	1C39	1C3A	1C3B	1C3C	REMARKS
1	5NY-25111-00	HUB, FRONT	1	1	1	1	
2	93306-90409	BEARING	2	2	2	2	
3	5NY-25117-00	SPACER, BEARING	1	1	1	1	
4	93102-26468	OIL SEAL	2	2	2	2	
5	94416-21005	RIM (1.60-21)	1	1	1	1	
6	5NY-25104-00	SPOKE SET, FRONT	1	1	1	1	
7	L.M.	TIRE (80/100-21 51M D739FA)				1	
8	L.M.	TUBE (80/100-21 M/C TR4)				1	
9	94309-21161	BAND, RIM (1.60-21)	1	1	1	1	DUNLOP
10	5SF-25394-00	SPACER, BEAD	1	1	1	1	
11	1C3-25181-10	AXLE, WHEEL	1	1	1	1	
12	5NY-25183-00	COLLAR, WHEEL	1	1	1	1	
13	5NY-25186-00	COLLAR, WHEEL	1	1	1	1	
14	90179-16011	NUT	1	1	1	1	



1C31100-D250

D10

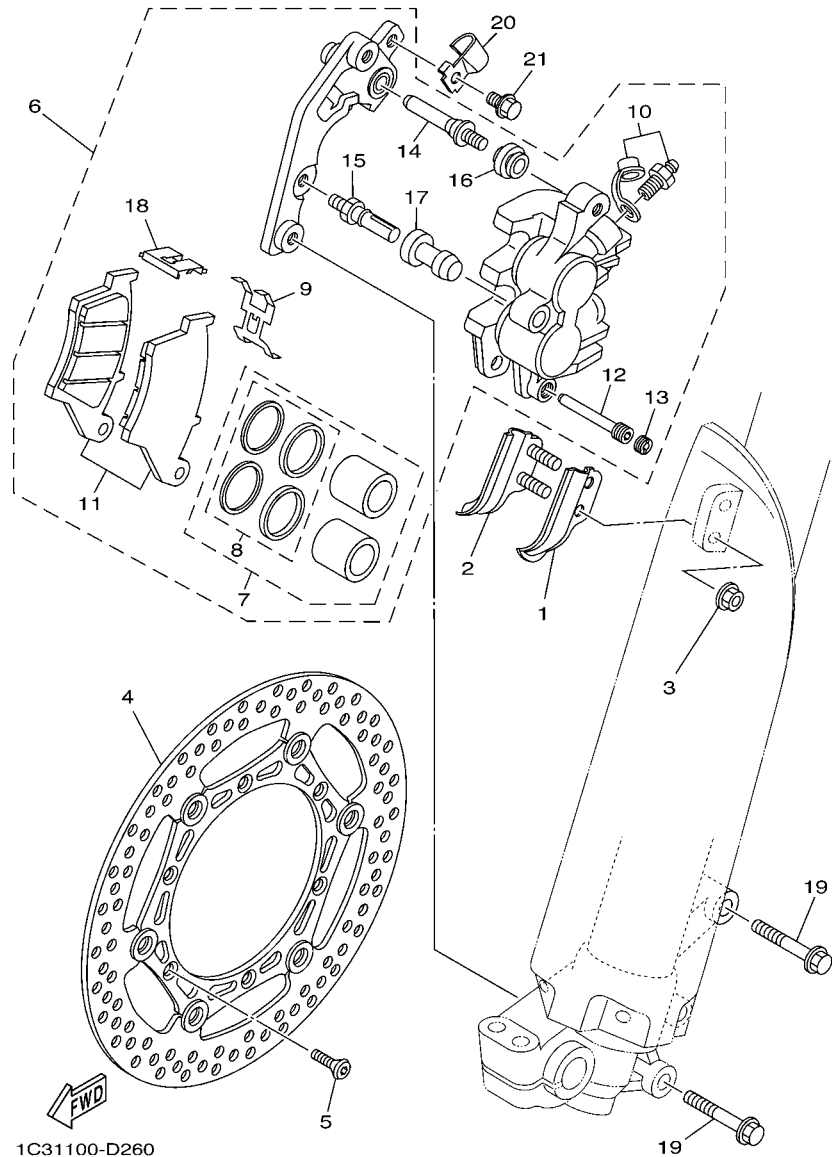
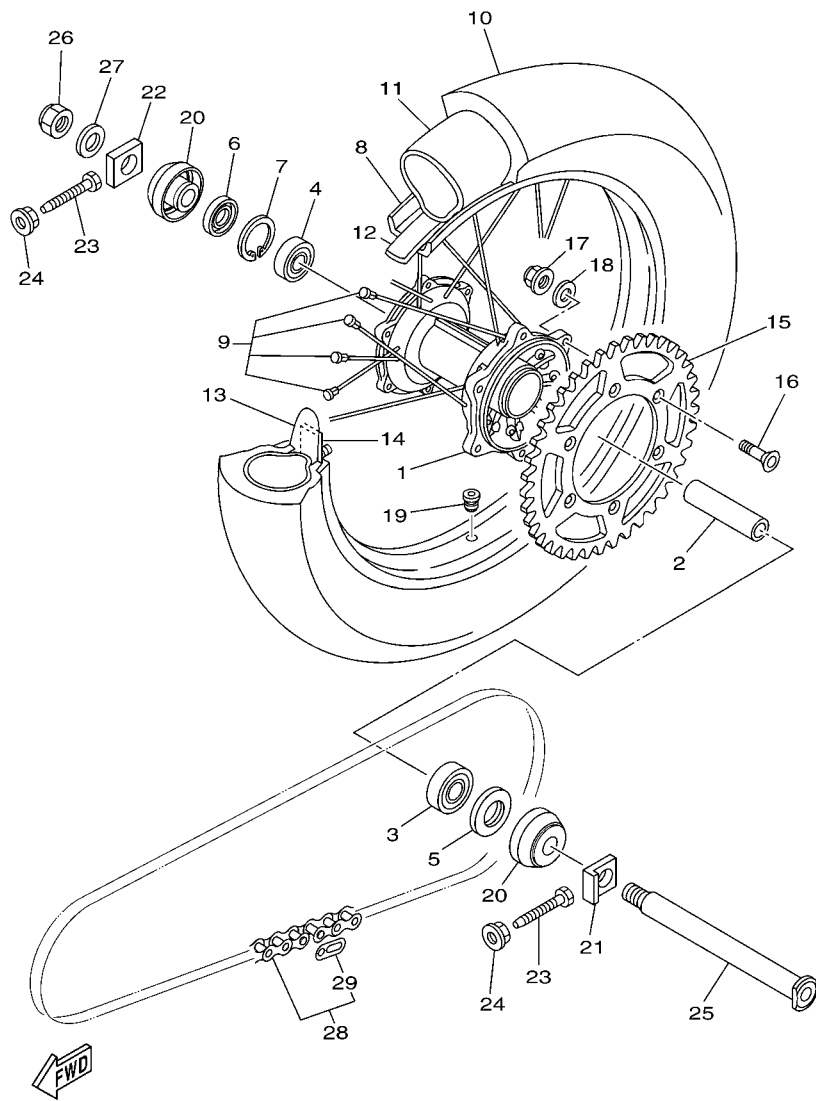

FIG. 26 FRONT BRAKE CALIPER

REF. NO.	PART NO.	DESCRIPTION	1C39	1C3A	1C3B	1C3C	REMARKS
1	1C3-23466-50	CLAMP	1	1	1	1	
2	1C3-23467-50	CLAMP	1	1	1	1	
3	95702-06500	NUT, FLANGE	2	2	2	2	
4	5MV-2581T-00	DISK BRAKE ASSY	1	1	1	1	
5	90149-06327	SCREW	6	6	6	6	
6	1C3-2580T-00	CALIPER ASSY (LEFT)	1	1	1	1	
7	5UN-W0057-00	.PISTON ASSY, CALIPER	1	1	1	1	
8	3JD-W0047-00	..CALIPER SEAL KIT	1	1	1	1	
9	5DH-25919-00	.SUPPORT, PAD	1	1	1	1	
10	1UY-W0048-50	.BLEED SCREW KIT	1	1	1	1	
11	5MV-W0045-01	.BRAKE PAD KIT	1	1	1	1	
12	5DH-25933-00	.PIN, PAD	1	1	1	1	
13	5DH-25916-00	.PLUG	1	1	1	1	
14	3SP-25926-51	.BOLT	1	1	1	1	
15	3SP-25914-51	.PIN, SLIDE	1	1	1	1	
16	3JD-25917-00	.BOOT, CALIPER	1	1	1	1	
17	1UY-25937-51	.BOOT 2	1	1	1	1	
18	5DH-25849-00	.RETAINER, CALIPER	1	1	1	1	
19	90105-08137	BOLT, FLANGE	2	2	2	2	
20	1C3-25875-50	HOLDER, BRAKE HOSE 1	1	1	1	1	
21	90105-06105	BOLT, FLANGE	1	1	1	1	



1C35100-E270

FIG. 27 REAR WHEEL

REF. NO.	PART NO.	DESCRIPTION	1C39	1C3A	1C3B	1C3C	REMARKS
1	5ET-25311-00	HUB, REAR	1	1	1	1	
2	5ET-25317-00	SPACER, BEARING	1	1	1	1	
3	93306-27212	BEARING	1	1	1	1	
4	93306-07202	BEARING	1	1	1	1	
5	93106-30001	OIL SEAL	1	1	1	1	
6	93106-30045	OIL SEAL	1	1	1	1	
7	99009-45500	CIRCLIP	1	1	1	1	
8	94418-19003	RIM (1.85-19)	1	1	1	1	
9	5HD-25304-00	SPOKE SET, REAR	1	1	1	1	
10	L.M.	TIRE (100/90-19 57M D756)				1	
11	L.M.	TUBE (100/90-19 M/C TR4 BTL)				1	
12	94321-19135	BAND, RIM (1.85-19)	1	1		1	DUNLOP
13	4XM-25394-00	SPACER, BEAD	1	1	1	1	
14	4XM-25364-00	DAMPER	1	1	1	1	
15	1C3-25448-00	SPROCKET, DRIVEN (48T)	1	1	1	1	STD
	1C3-25447-00	SPROCKET, DRIVEN (47T)	1	1	1	1	AP
	1C3-25449-00	SPROCKET, DRIVEN (49T)	1	1	1	1	AP
	1C3-25450-00	SPROCKET, DRIVEN (50T)	1	1	1	1	AP
	1C3-25451-00	SPROCKET, DRIVEN (51T)	1	1	1	1	AP
	1C3-25452-00	SPROCKET, DRIVEN (52T)	1	1	1	1	AP
16	90109-08078	BOLT	6	6	6	6	
17	90185-08008	NUT, SELF-LOCKING	6	6	6	6	
18	90201-08048	WASHER, PLATE	6	6	6	6	

FIG. 27 REAR WHEEL

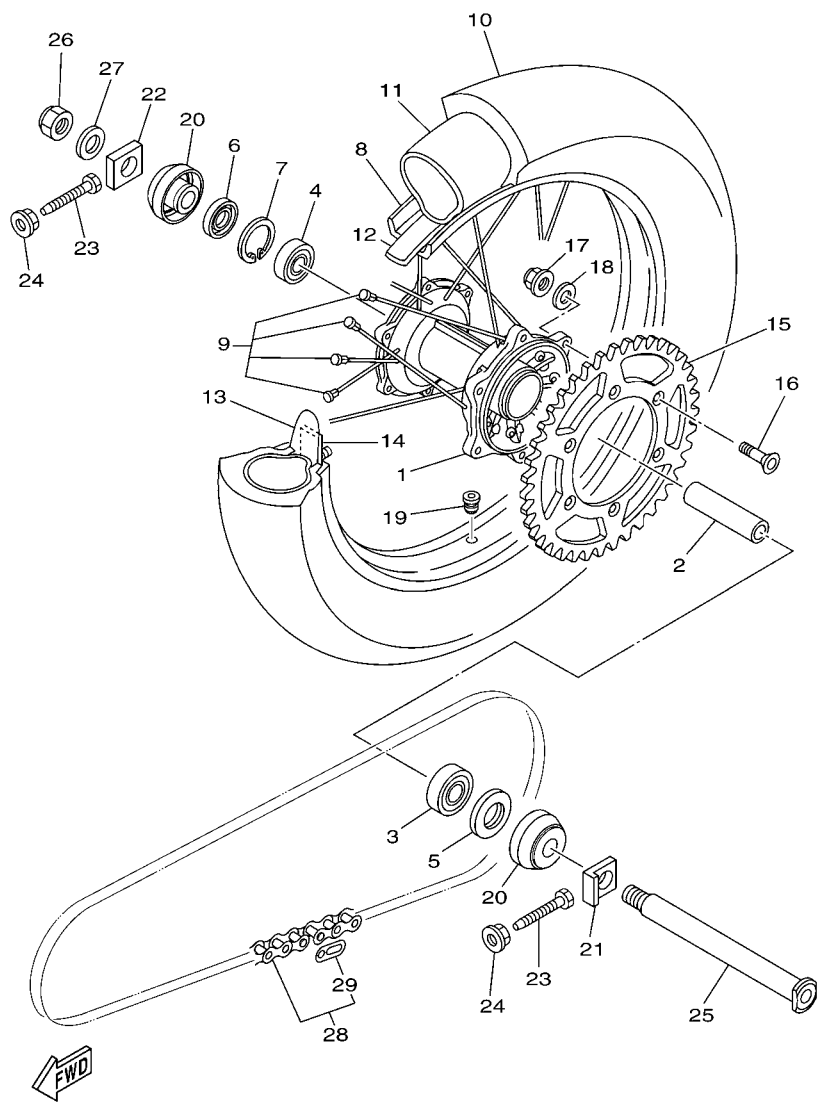

1C35100-E270

REF. NO.	PART NO.	DESCRIPTION	1C39	1C3A	1C3B	1C3C	REMARKS
19	90480-08608	GROMMET	1	1	1	1	
20	5TJ-2530S-80	COLLAR ASSY	2	2	2	2	
21	1C3-25388-50	PULLER, CHAIN 1	1	1	1	1	
22	1C3-25389-00	PULLER, CHAIN 2	1	1	1	1	
23	90101-08006	BOLT	2	2	2	2	
24	90179-08674	NUT	2	2	2	2	
25	1C3-25381-90	AXLE, WHEEL	1	1	1	1	
26	90185-20002	NUT, SELF-LOCKING	1	1	1	1	
27	90201-20020	WASHER, PLATE	1	1	1	1	
28	9Y581-92111	CHAIN (DID 520D 112L)	1	1	1	1	
29	94681-68001	.JOINT,CHAIN (DID 520DM-RJ)	1	1	1	1	

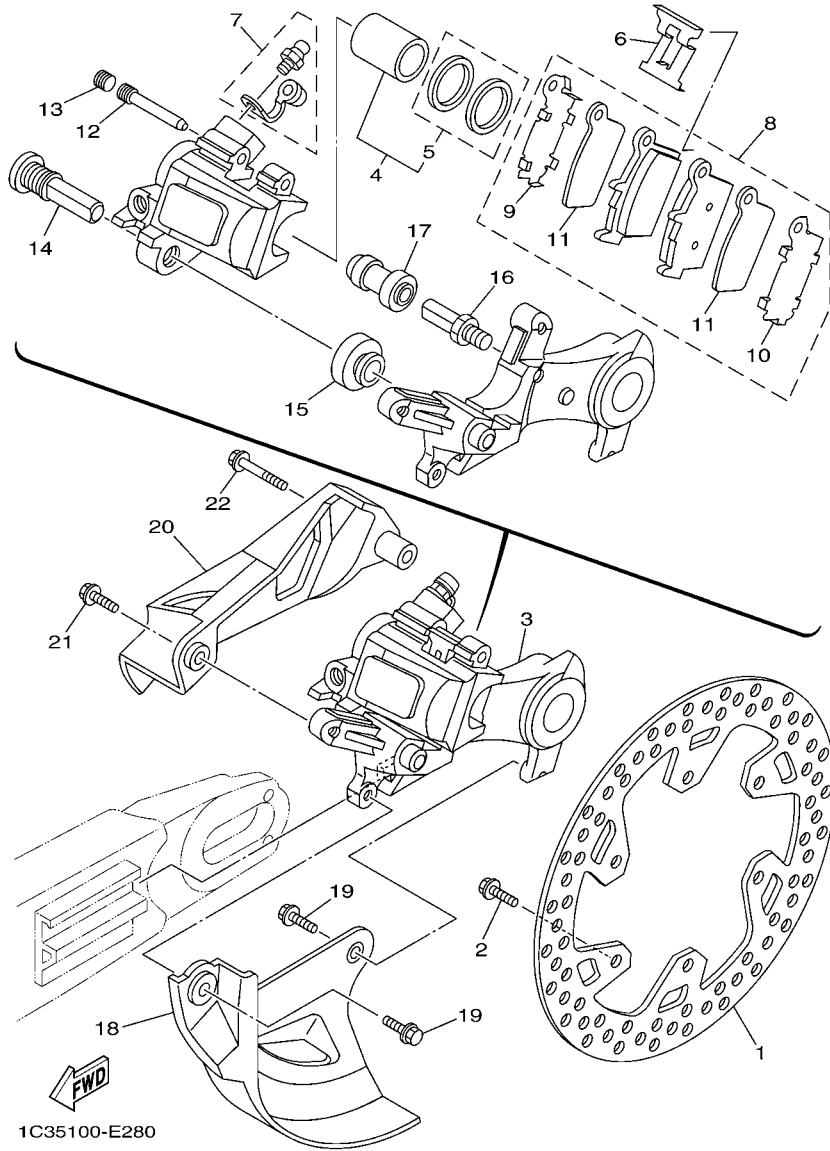
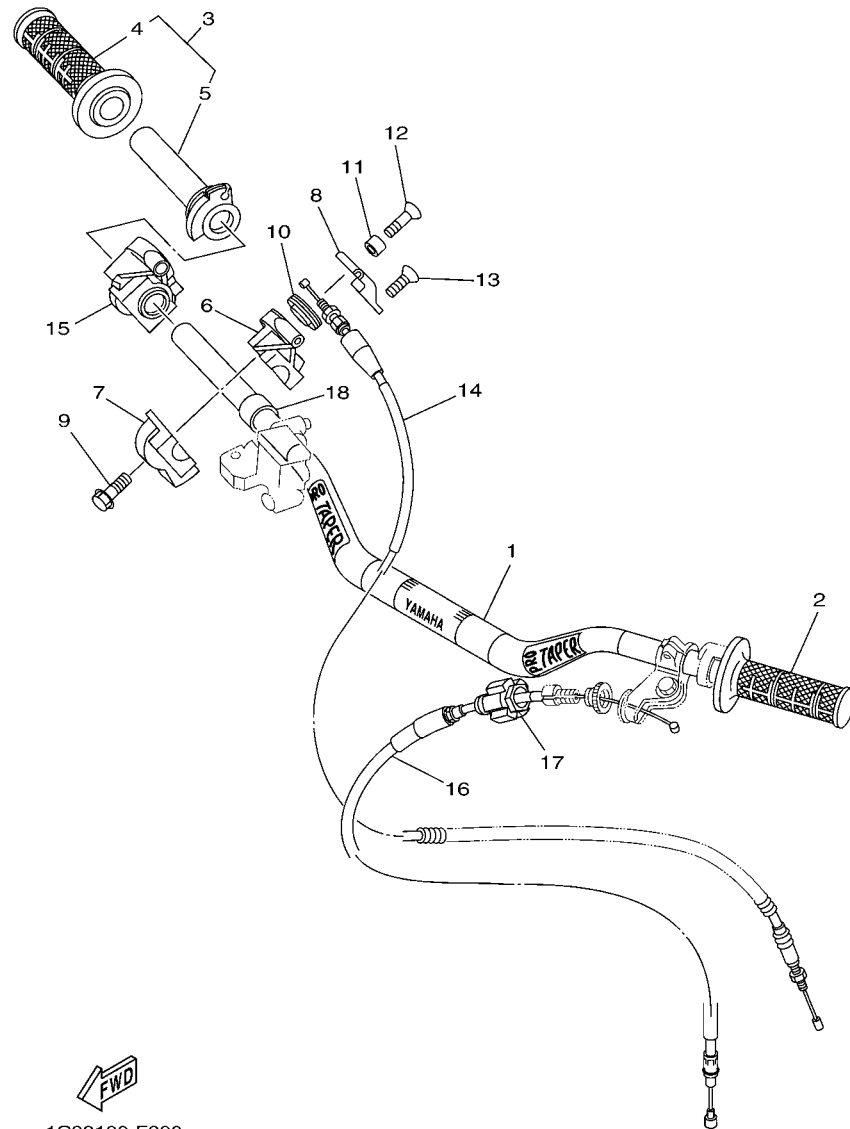

FIG. 28 REAR BRAKE CALIPER

REF. NO.	PART NO.	DESCRIPTION	1C39	1C3A	1C3B	1C3C	REMARKS
1	5NY-2582W-00	DISK, REAR BRAKE 2	1	1	1	1	
2	90105-06108	BOLT, FLANGE	6	6	6	6	
3	1C3-2580W-50	CALIPER ASSY, REAR 2	1	1	1	1	
4	5UN-W0057-50	.PISTON ASSY, CALIPER	1	1	1	1	
5	5UN-W0047-50	..CALIPER SEAL KIT	1	1	1	1	
6	5DH-25919-50	..SUPPORT, PAD	1	1	1	1	
7	1UY-W0048-50	.BLEED SCREW KIT	1	1	1	1	
8	1C3-W0046-50	.BRAKE PAD KIT 2	1	1	1	1	
9	5UN-25828-60	..SHIM, CALIPER	1	1	1	1	
10	5UN-25827-60	..SHIM, CALIPER	1	1	1	1	
11	5UN-22898-60	..INSULATOR, HEAT	2	2	2	2	
12	8CR-25924-00	.PIN, PAD	1	1	1	1	
13	5DH-25916-00	.PLUG	1	1	1	1	
14	5DH-25914-50	.PIN, SLIDE	1	1	1	1	
15	3JD-25917-00	.BOOT, CALIPER	1	1	1	1	
16	5UN-25914-00	.PIN, SLIDE	1	1	1	1	
17	1UY-25937-51	.BOOT 2	1	1	1	1	
18	1C3-25718-50	PROTECTOR, DISK BRAKE	1	1	1	1	
19	90105-06110	BOLT, FLANGE	2	2	2	2	
20	1C3-27491-50	PROTECTOR	1	1	1	1	
21	90105-06107	BOLT, FLANGE	1	1	1	1	
22	90105-06111	BOLT, FLANGE	1	1	1	1	



1C39100-F290

FIG. 29 STEERING HANDLE & CABLE

REF. NO.	PART NO.	DESCRIPTION	1C39	1C3A	1C3B	1C3C	REMARKS
1	1C3-26111-90	HANDLEBAR	1	1	1	1	
2	4GY-26241-00	GRIP	1	1	1	1	
3	4XM-26240-00	GRIP ASSY	1	1	1	1	
4	4GY-26242-00	.GRIP (RIGHT)	1	1	1	1	
5	4XM-26243-00	.TUBE, THROTTLE GUIDE	1	1	1	1	
6	1C3-26281-90	CAP, GRIP UPPER	1	1	1	1	
7	1C3-26282-90	CAP, GRIP LOWER	1	1	1	1	
8	1C3-2628H-90	CAP, WIRE	1	1	1	1	
9	90105-06112	BOLT, FLANGE	2	2	2	2	
10	1C3-26273-90	ROTOR	1	1	1	1	
11	90387-04003	COLLAR	1	1	1	1	
12	98680-04510	SCREW, OVAL HEAD	1	1	1	1	
13	98680-04516	SCREW, OVAL HEAD	1	1	1	1	
14	1C3-26311-90	CABLE, THROTTLE 1	1	1	1	1	
15	4SS-26287-01	COVER, CAP GRIP	1	1	1	1	
16	1C3-26335-90	CABLE, CLUTCH	1	1	1	1	
17	1C3-26342-50	BOOT, CABLE	1	1	1	1	
18	90387-227H7	COLLAR	1	1	1	1	

FIG. 30 FRONT MASTER CYLINDER

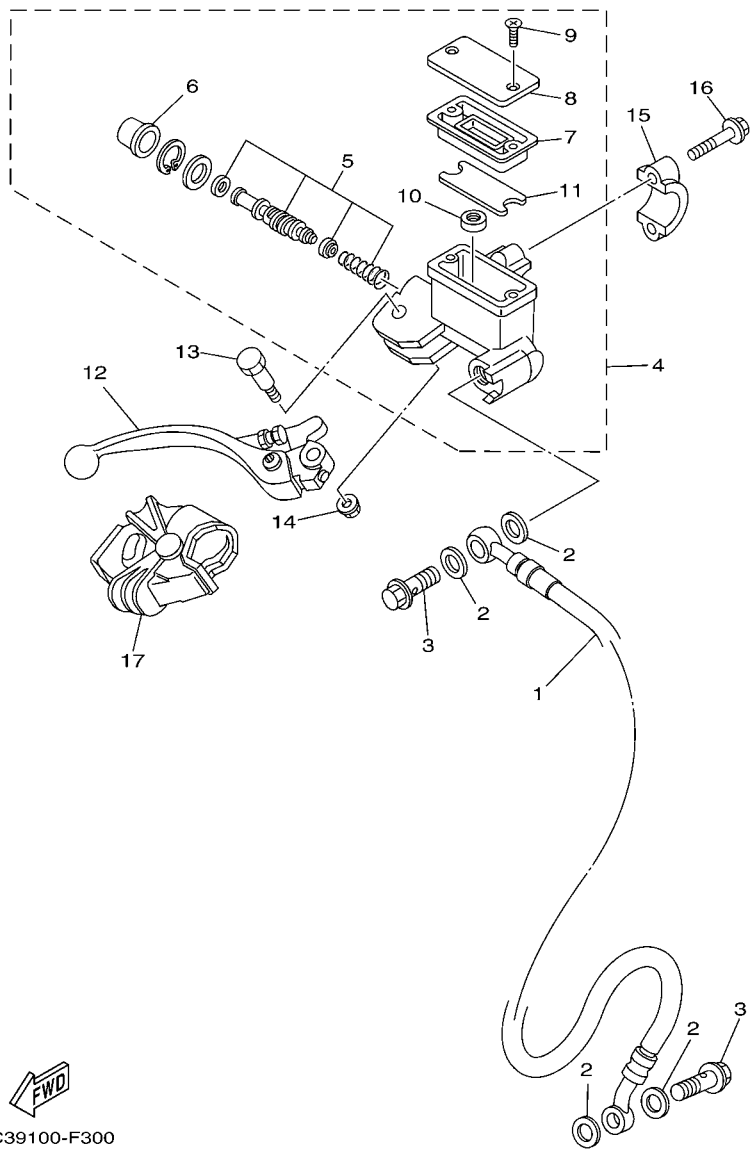



1C39100-F300

REF. NO.	PART NO.	DESCRIPTION	1C39	1C3A	1C3B	1C3C	REMARKS
1	1C3-25872-90	HOSE, BRAKE 1	1	1	1	1	
2	90430-10005	GASKET	4	4	4	4	
3	90401-10172	BOLT, UNION	2	2	2	2	
4	5XE-W2587-10	MASTER CYLINDER SUB ASSY	1	1	1	1	
5	5NY-W0041-00	.CYLINDER KIT, MASTER	1	1	1	1	
6	5NY-25868-00	.BOOT, MASTER CYLINDER	1	1	1	1	
7	5XE-25854-00	.DIAPHRAGM, RESERVOIR	1	1	1	1	
8	5MV-25852-01	.CAP, RESERVOIR	1	1	1	1	
9	98706-04012	.SCREW, FLAT HEAD	2	2	2	2	
10	5CG-25715-00	.SEPARATOR ASSY	1	1	1	1	
11	5XE-25853-00	.FLOAT, RESERVOIR	1	1	1	1	
12	1C3-83922-50	LEVER 2	1	1	1	1	
13	5MV-2589F-00	BOLT, LEVER	1	1	1	1	
14	95701-06500	NUT, FLANGE	1	1	1	1	
15	5MV-25867-00	BRACKET, MASTER CYLINDER	1	1	1	1	
16	5MV-25833-00	BOLT, FITTING	2	2	2	2	
17	5NY-26372-00	COVER, HANDLE LEVER 1	1	1	1	1	

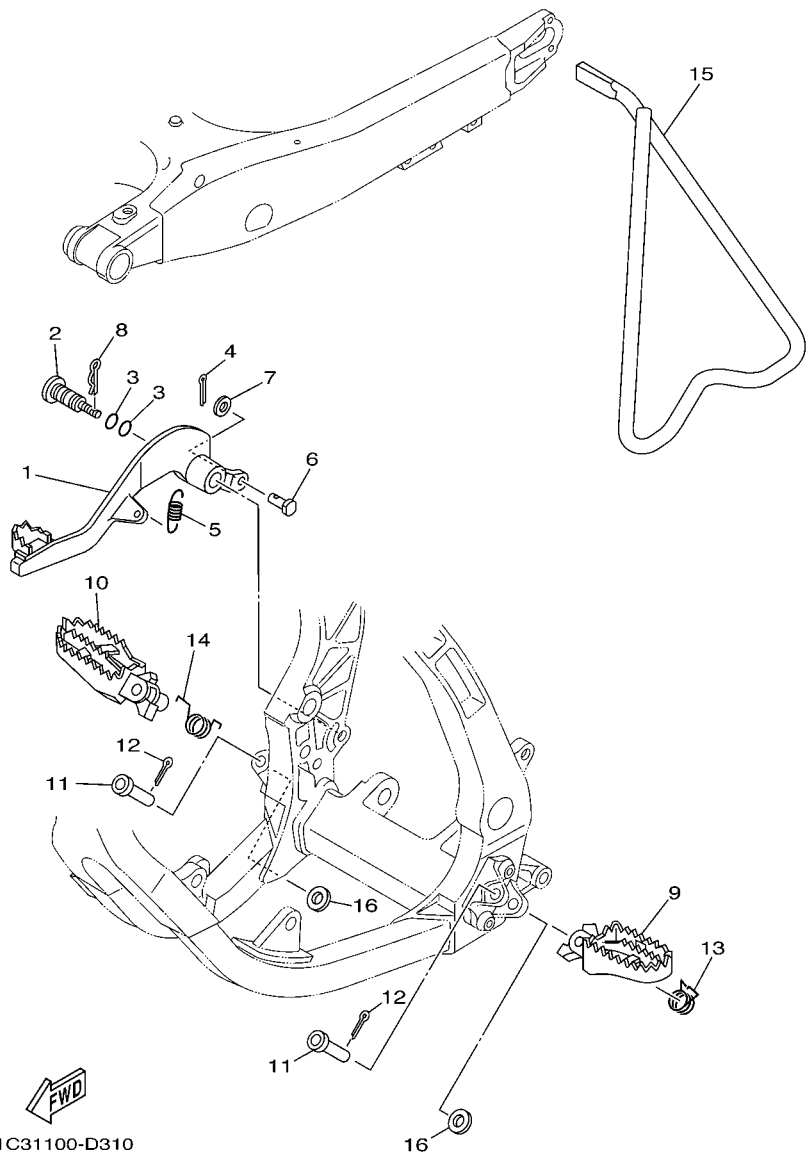
FIG. 31 STAND & FOOTREST

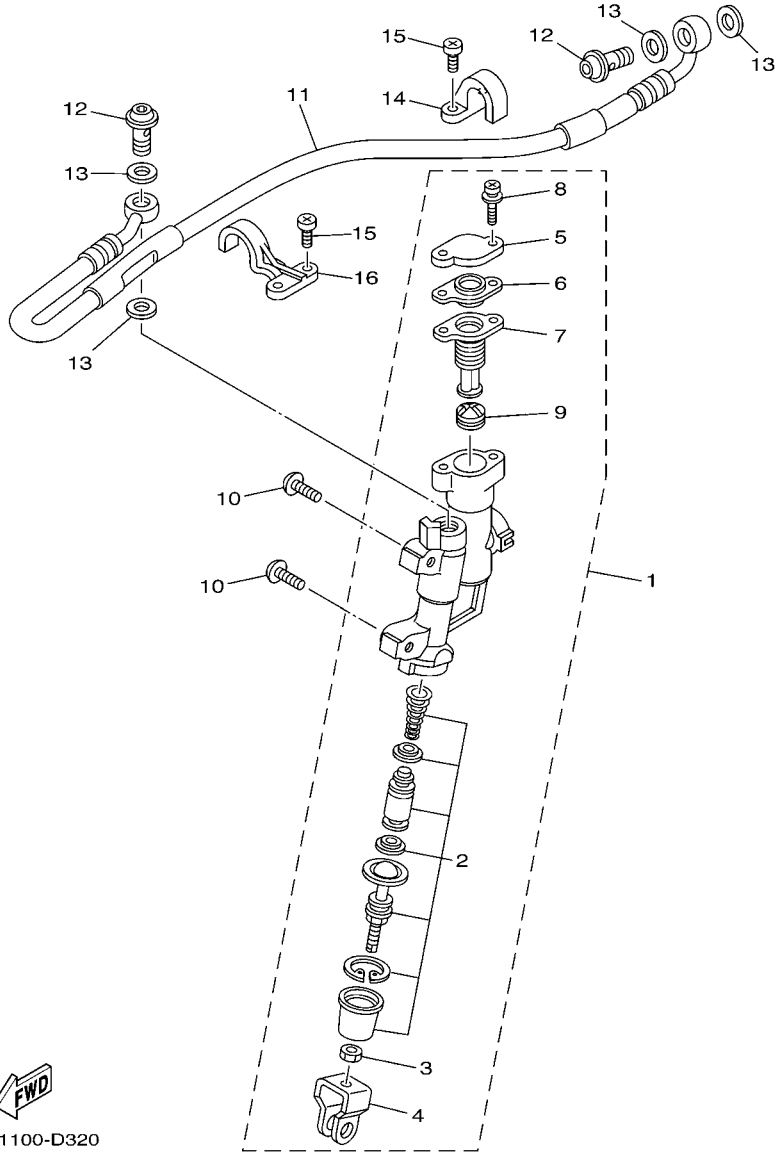

REF. NO.	PART NO.	DESCRIPTION	1C39	1C3A	1C3B	1C3C	REMARKS
1	4XM-27200-10	PEDAL, BRAKE	1	1	1	1	
2	1C3-27217-10	BOLT	1	1	1	1	
3	93210-11073	O-RING	2	2	2	2	
4	91402-20012	PIN, COTTER	1	1	1	1	
5	90506-16007	SPRING, TENSION	1	1	1	1	
6	90240-08120	PIN, CLEVIS	1	1	1	1	
7	90201-08044	WASHER, PLATE	1	1	1	1	
8	90468-16001	CLIP	1	1	1	1	
9	5XE-27411-01	FOOTREST 1	1	1	1	1	
10	5XE-27421-01	FOOTREST 2	1	1	1	1	
11	90240-10004	PIN, CLEVIS	2	2	2	2	
12	91402-25015	PIN, COTTER	2	2	2	2	
13	90508-28015	SPRING, TORSION	1	1	1	1	
14	90508-28018	SPRING, TORSION	1	1	1	1	
15	1C3-27311-00	STAND, SIDE	1	1	1	1	
16	90201-10032	WASHER, PLATE	2	2	2	2	



1C31100-D320

FIG. 32 REAR MASTER CYLINDER

REF. NO.	PART NO.	DESCRIPTION	1C39	1C3A	1C3B	1C3C	REMARKS
1	1C3-2583V-00	RR. MASTER CYLINDER ASSY.	1	1	1	1	
2	5UN-W0042-50	.CYLINDER KIT, MASTER	1	1	1	1	
3	5UN-27218-00	.NUT	1	1	1	1	
4	5UN-27222-00	.JOINT	1	1	1	1	
5	5UN-25852-50	.CAP, RESERVOIR	1	1	1	1	
6	5UN-2585B-00	.PLATE, DIAPHRAGM	1	1	1	1	
7	5UN-25854-00	.DIAPHRAGM, RESERVOIR	1	1	1	1	
8	5UN-27217-00	.BOLT	2	2	2	2	
9	5CG-25715-00	.SEPARATOR ASSY	1	1	1	1	
10	90111-06059	BOLT,HEX. SOCKET BUTTON	2	2	2	2	
11	1C3-25873-00	HOSE, BRAKE 2	1	1	1	1	
12	90401-10172	BOLT, UNION	2	2	2	2	
13	90430-10005	GASKET	4	4	4	4	
14	1C3-25886-50	HOLDER, BRAKE HOSE	1	1	1	1	
15	98502-05010	SCREW, PAN HEAD	4	4	4	4	
16	1C3-25876-50	HOLDER, BRAKE HOSE 2	1	1	1	1	

FIG. 33 GENERATOR

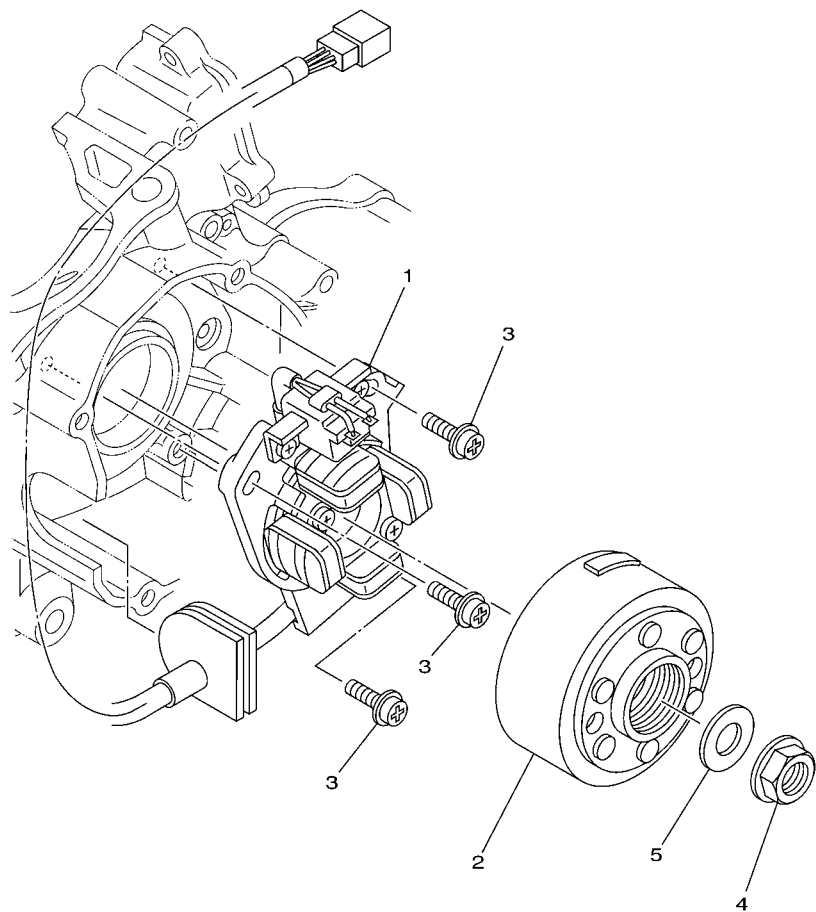

REF. NO.	PART NO.	DESCRIPTION	1C39	1C3A	1C3B	1C3C	REMARKS
1	1C3-85560-10	BASE ASSY	1	1	1	1	
2	1C3-85550-01	ROTOR ASSY	1	1	1	1	
3	90149-06108	SCREW	3	3	3	3	
4	90179-12004	NUT	1	1	1	1	
5	90201-127E1	WASHER, PLATE	1	1	1	1	

1C31100-D330

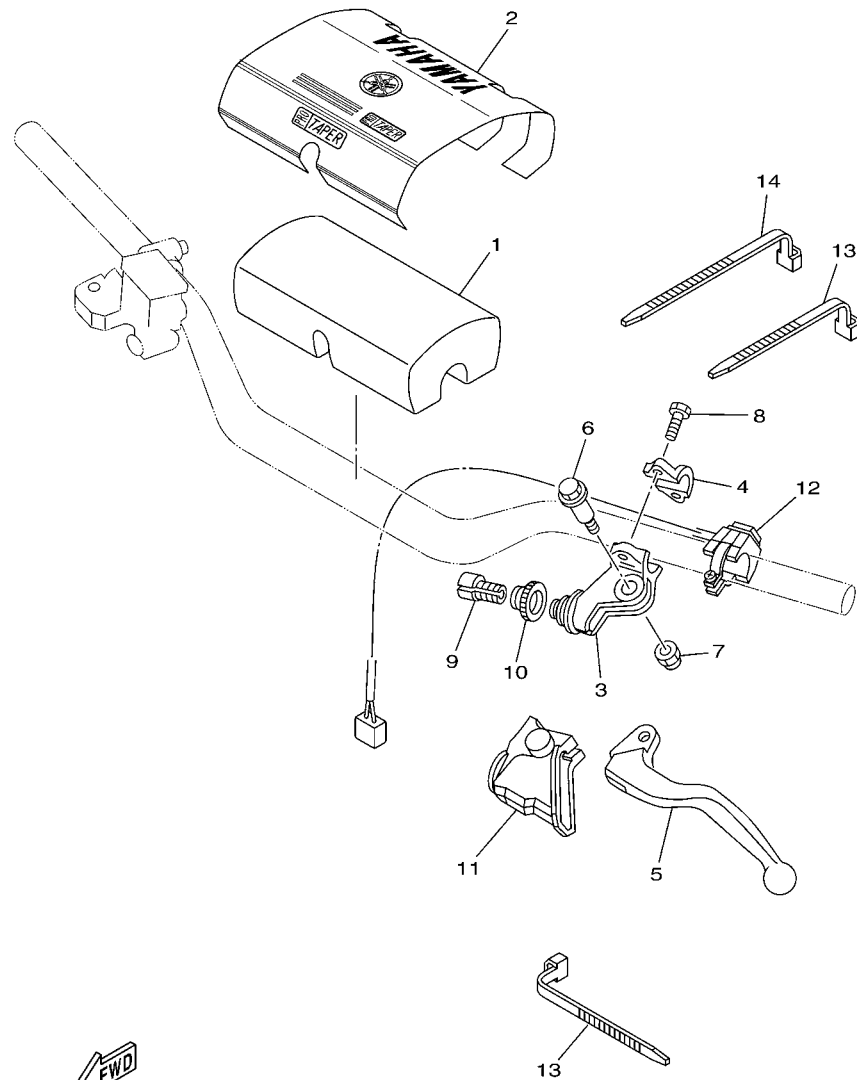



 1C39100-F340

FIG. 34 HANDLE SWITCH & LEVER

REF. NO.	PART NO.	DESCRIPTION	1C39	1C3A	1C3B	1C3C	REMARKS
1	5XC-26124-90	PROTECTOR, HANDLEBAR	1	1	1	1	
2	5XC-26143-90	COVER, HANDLEBAR UPPER 1	1	1	1	1	
3	5XE-82911-00	HOLDER, LEVER 1	1	1	1	1	
4	5TG-82913-00	HOLDER, LEVER LOWER 1	1	1	1	1	
5	5MV-83912-00	LEVER 1	1	1	1	1	
6	90109-06034	BOLT	1	1	1	1	
7	5LP-84126-10	NUT, LENS FITTING	1	1	1	1	
8	90101-05033	BOLT	2	2	2	2	
9	5HD-26337-00	BOLT, ADJUSTING	1	1	1	1	
10	5HD-83951-00	BOLT, CABLE ADJUSTING	1	1	1	1	
11	5HD-26372-00	COVER, HANDLE LEVER 1	1	1	1	1	
12	1C3-83976-00	SWITCH, HANDLE 1	1	1	1	1	
13	90464-13077	CLAMP	2	2	2	2	
14	90464-13073	CLAMP	1	1	1	1	

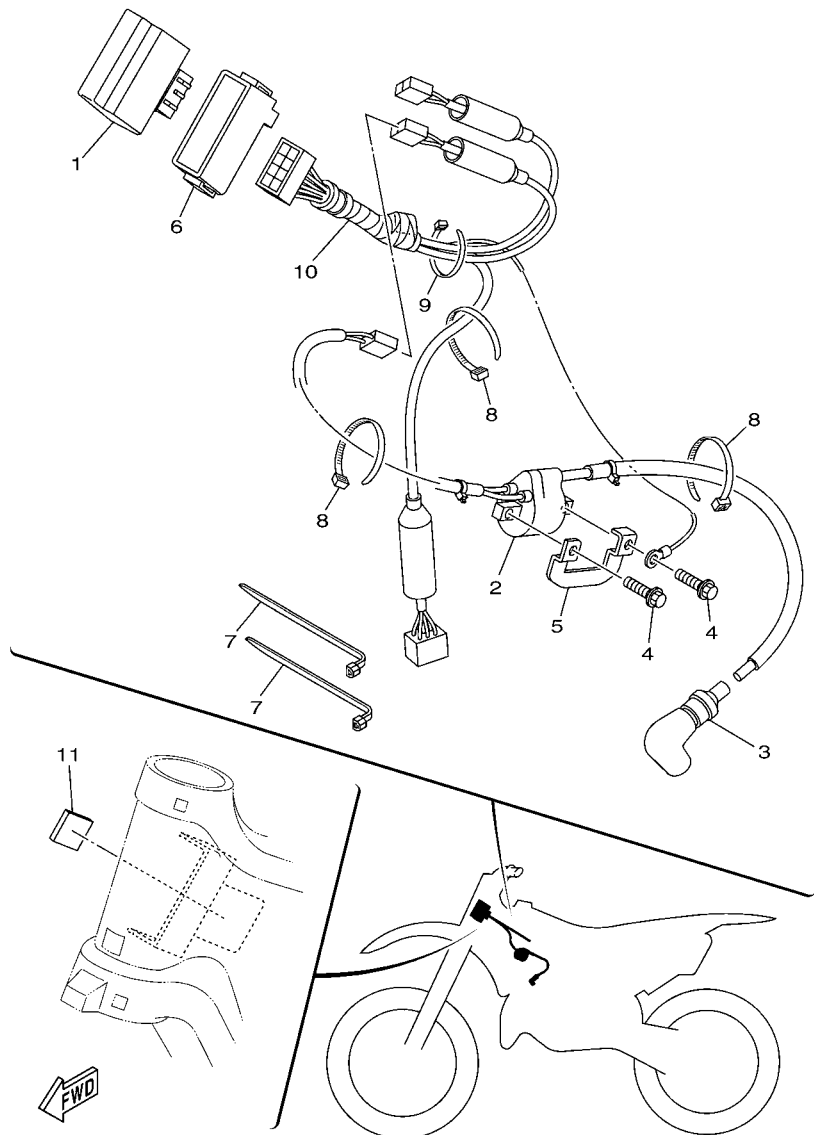
FIG. 35 ELECTRICAL 1



1C39100-F350

REF. NO.	PART NO.	DESCRIPTION	1C39	1C3A	1C3B	1C3C	REMARKS
1	1C3-85540-10	C.D.I. UNIT ASSY	1	1	1	1	
2	1C3-82320-00	IGNITION COIL ASSY	1	1	1	1	
3	8DG-82370-00	.PLUG CAP ASSY	1	1	1	1	
4	90105-06060	BOLT, FLANGE	2	2	2	2	
5	1C3-8231U-10	CORE, SIDE	1	1	1	1	
6	1C3-85546-00	BAND	1	1	1	1	
7	90464-15195	CLAMP	2	2	2	2	
8	90465-13275	CLAMP	3	3	3	3	
9	5Y9-12491-00	CLAMP 1	1	1	1	1	
10	1C3-82509-10	WIRE, SUB LEAD	1	1	1	1	
11	1C3-2139X-00	DAMPER	1	1	1	1	

FIG. 36 ALTERNATE FOR CHASSIS

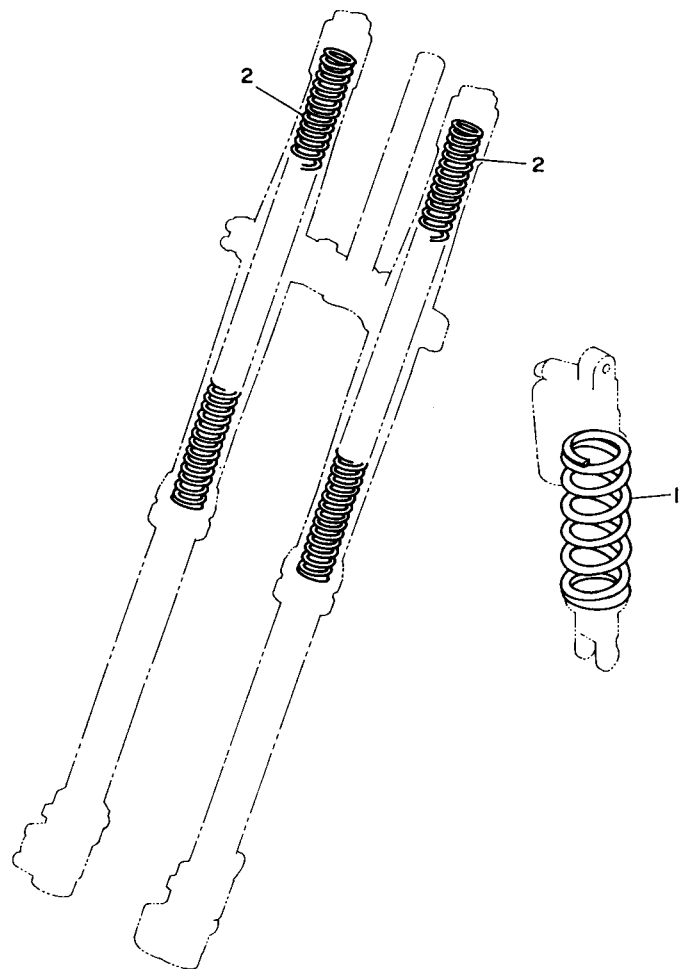

3JD1010-9360

REF. NO.	PART NO.	DESCRIPTION	1C39	1C3A	1C3B	1C3C	REMARKS
1	5UN-22212-00	SPRING (K=42N/MM)	1	1	1	1	AP
	1C3-22212-00	SPRING (K=44N/MM)	1	1	1	1	AP
	1C3-22212-20	SPRING (K=48N/MM)	1	1	1	1	AP
	1C3-22212-30	SPRING (K=50N/MM)	1	1	1	1	AP
	5UN-22212-50	SPRING (K=52N/MM)	1	1	1	1	AP
	5UN-22212-60	SPRING (K=54N/MM)	1	1	1	1	AP
	5UN-22212-70	SPRING (K=56N/MM)	1	1	1	1	AP
	5UN-22212-A0	SPRING (K=APPROX.44N/MM)	1	1	1	1	AP
	5UN-22212-B0	SPRING (K=APPROX.46N/MM)	1	1	1	1	AP
	5UN-22212-C0	SPRING (K=APPROX.48N/MM)	1	1	1	1	AP
	5UN-22212-D0	SPRING (K=APPROX.50N/MM)	1	1	1	1	AP
	5UN-22212-E0	SPRING (K=APPROX.52N/MM)	1	1	1	1	AP
	5UN-22212-F0	SPRING (K=APPROX.54N/MM)	1	1	1	1	AP
	5UN-22212-G0	SPRING (K=APPROX.56N/MM)	1	1	1	1	AP
2	1C3-23141-A0	SPRING, FRONT FORK(K=3.9N/MM)	2	2	2	2	AP
	1C3-23141-C0	SPRING, FRONT FORK(K=4.1N/MM)	2	2	2	2	AP
	1C3-23141-D0	SPRING, FRONT FORK(K=4.2N/MM)	2	2	2	2	AP
	1C3-23141-E0	SPRING, FRONT FORK(K=4.3N/MM)	2	2	2	2	AP
	1C3-23141-F0	SPRING, FRONT FORK(K=4.4N/MM)	2	2	2	2	AP
	1C3-23141-G0	SPRING, FRONT FORK(K=4.5N/MM)	2	2	2	2	AP
	1C3-23141-H0	SPRING, FRONT FORK(K=4.6N/MM)	2	2	2	2	AP
	1C3-23141-J0	SPRING, FRONT FORK(K=4.7N/MM)	2	2	2	2	AP

NUMERICAL INDEX

PART NO.	GRID NO.	PART NO.	GRID NO.	PART NO.	GRID NO.	PART NO.	GRID NO.	PART NO.	GRID NO.	PART NO.	GRID NO.
1C3-11111-10	B - 2	1C3-12481-00	B - 7	137-14143-84	B - 10	4JT-15381-01	C - 4	1C3-18512-00	C - 6	30X-22178-00	C - 8
4JY-11166-00	B - 2	1C3-12482-00	B - 7	137-14143-86	B - 10	1C3-15411-10	B - 15	1C3-18513-00	C - 6	3JD-22178-20	C - 8
1C3-11311-10	B - 2	1C3-12483-00	B - 7	137-14143-88	B - 11	1C3-15415-00	B - 15	3XV-18531-00	C - 6	1C3-2217A-00	C - 13
1C3-1131D-00	B - 2	1C3-12484-00	B - 7	137-14143-90	B - 11	1C3-15421-10	B - 15	4JG-18531-00	C - 6	1C3-2217F-50	C - 13
4SS-1131M-01	B - 2	5Y9-12491-00	E - 7	137-14143-92	B - 11	1C3-15431-00	B - 15	1C3-18541-00	C - 6	4V4-22184-00	C - 8
5HD-1131V-00	B - 2	353-13115-01	B - 14	137-14143-94	B - 11	1C3-15451-00	B - 15	1C3-18562-00	C - 6	5MV-22184-00	C - 15
1C3-1132D-00	B - 2	1C3-13565-00	B - 8	51R-14146-00	B - 11	1C3-15462-00	B - 15	1C3-21101-50	C - 8	1C3-22199-10	C - 13
1C3-11351-00	B - 2	1C3-13610-10	B - 8	5MV-14146-00	B - 11	1C3-15463-00	B - 15	5PA-2118K-00	C - 10	1C3-22200-A0	C - 15
1C3-11354-00	B - 2	5UN-13613-00	B - 8	2K6-14147-00	B - 9	4DB-15620-10	C - 2	5PA-2118K-10	C - 10	1C3-22200-B0	C - 15
5UN-11395-00	B - 2	5MV-13616-10	B - 8	5ET-14147-00	B - 11	4DB-15621-03	C - 2	5PA-2118K-20	C - 10	1C3-22200-C0	C - 15
1C3-11400-20	B - 5	1C3-13625-00	B - 8	3MA-14159-00	B - 9	1C3-15641-00	C - 2	1C3-21190-90	C - 8	1C3-22200-D0	C - 15
1C3-11410-10	B - 5	1C3-14101-30	B - 9	5ET-1416A-00	B - 11	1C3-15651-00	C - 2	1C3-21244-10	C - 9	1C3-22200-E0	C - 15
1C3-11420-20	B - 5	1C3-14101-40	B - 9	3JE-14171-00	B - 9	1C3-15660-00	C - 2	1C3-21336-00	C - 8	1C3-22201-A0	C - 15
5NY-11611-00	B - 5	1C3-14101-50	B - 9	5NY-14181-00	B - 11	1C3-15666-00	C - 2	1C3-2135F-00	C - 14	1C3-22201-B0	C - 15
	E - 9	4PE-14103-00	B - 9	5ET-14185-00	B - 9	1C3-16111-00	C - 3	1C3-2139R-00	C - 14	1C3-22212-00	E - 8
1C3-11630-00	E - 9	5UN-14104-00	B - 9	353-14186-00	B - 9	1C3-16150-00	C - 3	1C3-2139X-00	E - 7	5UN-22212-00	E - 8
1C3-11631-00-B0	E - 9	4PE-14107-38	B - 9	4PE-14194-00	B - 9	1C3-16181-00	C - 3	1C3-21425-00	C - 8	1C3-22212-10	C - 15
1C3-11631-01-A0	B - 5	1C3-14112-40	B - 11	5MV-14194-00	B - 11	3XJ-16321-00	C - 3	1C3-21447-10	C - 8	1C3-22212-20	E - 8
1C3-11631-01-B0	B - 5	1C3-14112-42	B - 11	10V-14196-00	B - 9	3XJ-16324-01	C - 3	1C3-21448-10	C - 8	1C3-22212-30	E - 8
1C3-11631-01-C0	B - 5	5ET-14115-00	B - 9	2HH-14197-00	B - 11	5HD-16351-00	C - 3	1C3-21511-51	C - 10	5UN-22212-50	E - 8
1C3-11631-01-D0	B - 5	284-14116-H2	B - 9	5ET-14197-00	B - 9	5NL-16356-00	C - 3	4LB-2151H-02	C - 10	5UN-22212-60	E - 8
1C3-11633-00	B - 5	284-14116-H3	B - 9	5MV-14216-00	B - 11	1C3-16357-10	C - 3	3XJ-2151H-A1	C - 10	5UN-22212-70	E - 8
	E - 9	284-14116-H4	B - 9	5HD-14261-00	B - 9	5NY-16371-00	C - 3	3XJ-2151H-B1	C - 11	5UN-22212-A0	E - 8
1C3-11650-00	E - 9	284-14116-H5	B - 9	5MV-14261-00	B - 11	1C3-16380-00	C - 3	4XL-2153A-10	D - 6	5UN-22212-B0	E - 8
1C3-11651-00	B - 5	284-14116-H6	B - 10	5ET-14261-01	B - 9	1C3-17121-10	C - 4	4ES-2153E-01	C - 10	5UN-22212-C0	E - 8
	E - 9	284-14116-J2	B - 10	5NY-14401-01	B - 8	1C3-17131-10	C - 4	5PA-21568-00	C - 10	5UN-22212-D0	E - 8
3JD-11681-10	B - 5	284-14116-J3	B - 10	5NY-14417-00	B - 8	1C3-17151-10	C - 4	5XE-21610-10	C - 10	5UN-22212-E0	E - 8
	E - 9	284-14116-J4	B - 9	5NY-14442-00	B - 8	1C3-17161-10	C - 4	5XE-21635-10	C - 10	5UN-22212-F0	E - 8
4SS-11832-00	B - 2	284-14116-J5	B - 10	4XM-14451-00	B - 8	1C3-17211-10	C - 4	1C3-2163G-00	C - 10	5UN-22212-G0	E - 8
5CU-11911-00	B - 4	284-14116-J6	B - 10	1C3-14453-10	B - 8	1C3-17221-10	C - 4	5UN-21642-10	C - 10	1C3-22213-L0	C - 15
5CU-11912-00	B - 4	284-14116-K2	B - 10	5NY-14455-20	B - 8	1C3-17231-20	C - 4	3RV-21668-A0	C - 14	1C3-22214-50	C - 15
4JY-11915-10	B - 4	284-14116-K3	B - 10	3JD-14458-01	B - 8	1C3-17241-10	C - 4	3RV-21668-B0	C - 14	5MV-22224-00	C - 15
5X4-11921-02	B - 4	284-14116-K4	B - 10	5NY-14459-00	B - 8	1C3-17251-10	C - 4	5NY-21711-00	C - 12	4JX-22226-00	C - 15
3JE-11922-01	B - 4	284-14116-K5	B - 10	1FN-14565-00	B - 9	1C3-17261-10	C - 4	5GJ-21717-00	C - 8	3SP-22234-00	C - 15
5CU-11952-00	B - 4	284-14116-K6	B - 10	1C3-14610-00	B - 12	1C3-17411-10	C - 4	5NY-21721-00	C - 12	5NY-22241-00	D - 2
5NY-11953-00	B - 4	4PE-14131-00	B - 9	4JY-14615-00	B - 12	1C3-17421-00	C - 4	1C3-21721-50	C - 12	5XE-22242-00	D - 2
1C3-11990-10	B - 4	87M-14137-00	B - 11	5MV-14642-00	B - 12	1C3-17466-00	B - 15	5NL-2172A-20	C - 12	1C3-22253-50	C - 15
1C3-11992-00	B - 3	4KM-14142-30	B - 10	1C3-1469A-00	B - 12	1C3-18101-00	C - 7	5XE-21730-00	C - 12	1C3-22253-L0	C - 15
1C3-11993-00	B - 3	4KM-14142-32	B - 10	5NY-1469A-00	B - 12	1C3-18110-00	C - 7	1C3-2173E-20	C - 12	4AA-22259-40	C - 15
1C3-11995-00	B - 3	4KM-14142-35	B - 10	1C3-14753-00	B - 12	5LP-18122-01	C - 7	1C3-2173F-20	C - 12	4AA-22259-50	C - 15
1C3-1240A-00	B - 7	4KM-14142-37	B - 10	5XE-14753-10	B - 12	1C3-18140-10	C - 6	5XE-21740-00	C - 12	4AA-22259-60	C - 15
1C3-12422-00	B - 6	4KM-14142-40	B - 10	1C3-14763-00	B - 12	1C3-18172-00	C - 7	1C3-22110-50	C - 13	4AA-22259-80	C - 15
1C3-12428-00	B - 6	4KM-14142-42	B - 10	565-14771-00	B - 12	3XJ-18173-10	C - 7	1C3-22121-00	C - 14	1C3-22355-00	C - 13
1C3-12450-00	B - 6	4KM-14142-45	B - 10	5CU-14771-01	B - 12	3XJ-18178-00	C - 7	1C3-22122-00	C - 14	4EW-22474-00	C - 15
1C3-12453-10	B - 6	4KM-14142-47	B - 10	1C3-15111-01	B - 14	3XJ-18182-00	C - 7	1C3-22128-00	C - 13	3JE-22475-00	C - 15
1C3-12461-00	B - 7	4KM-14142-50	B - 10	4V4-15118-00	B - 14	3XJ-18184-00	C - 7	1C3-22141-10	C - 13	5NY-22475-00	C - 15
22W-12462-00	B - 7	137-14143-80	B - 10	1C3-15121-00	B - 14	1C3-18185-00	C - 7	1C3-22151-00	C - 13	1C3-22565-00	C - 15
1C3-12465-00	B - 7	137-14143-82	B - 10	3Y1-15363-00	B - 15	1C3-18511-00	C - 6	5UN-22176-00	C - 15	5UN-22898-60	D - 14

NUMERICAL INDEX

PART NO.	GRID NO.	PART NO.	GRID NO.	PART NO.	GRID NO.	PART NO.	GRID NO.	PART NO.	GRID NO.	PART NO.	GRID NO.
1C3-22969-90	C - 13	5XC-23441-90	D - 3	1C3-25449-00	D - 12	4GY-26241-00	D - 15	5UN-W0057-50	D - 14	90149-06108	D - 7
1C3-23102-A0	D - 4	5XC-23442-90	D - 3	1C3-25450-00	D - 12	4GY-26242-00	D - 15	5XE-W2587-10	E - 2		E - 5
1C3-23102-B0	D - 4	1C3-23466-50	D - 11	1C3-25451-00	D - 12	4XM-26243-00	D - 15	90101-05033	E - 6	90149-06327	D - 11
1C3-23103-A0	D - 5	1C3-23467-50	D - 11	1C3-25452-00	D - 12	1C3-26273-90	D - 15	90101-06041	C - 7	90149-10031	C - 8
1C3-23103-B0	D - 5	1C3-23485-61	D - 3	5CG-25715-00	E - 2	1C3-26281-90	D - 15	90101-08006	D - 13	90151-04003	C - 13
5XC-23110-L0	D - 5	1C3-24110-90	D - 7		E - 4	1C3-26282-90	D - 15	90105-06060	E - 7	90151-06045	C - 2
1C3-23111-L1	D - 4	4EW-2412F-00	D - 7	1C3-25718-50	D - 14	4SS-26287-01	D - 15	90105-06064	C - 12	90159-06016	C - 3
276-23114-00	D - 4	5XE-24144-00	D - 7	1C3-2580T-00	D - 11	1C3-2628H-90	D - 15	90105-06081	C - 6	90159-06021	C - 12
5XC-23120-L0	D - 4	3ME-2415E-01	C - 10	1C3-2580W-50	D - 14	1C3-26311-90	D - 15	90105-06085	B - 14	90170-16326	C - 3
5XE-23125-L0	D - 4	3XJ-2415E-A0	C - 10	5MV-2581T-00	D - 11	1C3-26335-90	D - 15	90105-06099	C - 10	90170-24003	D - 3
1C3-23136-N0	D - 4	3XJ-2415E-B0	C - 10	5UN-25827-60	D - 14	5HD-26337-00	E - 6	90105-06101	C - 10	90176-08005	B - 2
1C3-23141-A0	E - 8	3XJ-2415E-C0	C - 10	5UN-25828-60	D - 14	1C3-26342-50	D - 15	90105-06103	C - 12	90179-06028	C - 13
1C3-23141-C0	E - 8	4SR-2416E-00	C - 10	5NY-2582W-00	D - 14	5HD-26372-00	E - 6	90105-06104	C - 13	90179-08019	B - 2
1C3-23141-D0	E - 8	3SP-24173-00	D - 7	5MV-25833-00	E - 2	5NY-26372-00	E - 2	90105-06105	C - 13	90179-08674	C - 9
1C3-23141-E0	E - 8	5XE-24176-10	D - 7	1C3-2583V-00	E - 4	4XM-27200-10	E - 3		D - 11		D - 13
1C3-23141-F0	E - 8	1C3-24181-00	D - 7	5DH-25849-00	D - 11	5UN-27217-00	E - 4	90105-06107	D - 6	90179-10658	C - 8
1C3-23141-G0	E - 8	1C3-24182-00	D - 7	5MV-25852-01	E - 2	1C3-27217-10	E - 3		D - 7	90179-12004	E - 5
1C3-23141-H0	E - 8	1C3-24183-00	D - 7	5UN-25852-50	E - 4	5UN-27218-00	E - 4		D - 14	90179-16011	D - 10
1C3-23141-J0	E - 8	1C3-24184-00	D - 8	5XE-25853-00	E - 2	5UN-27222-00	E - 4	90105-06108	D - 14	90179-18001	C - 5
1C3-23141-N1	D - 4	5NY-24186-00	D - 7	5UN-25854-00	E - 4	1C3-27311-00	E - 3	90105-06110	D - 14	90179-28003	D - 3
1C3-23142-L0	D - 4	1C3-24240-20	D - 7	5XE-25854-00	E - 2	5XE-27411-01	E - 3	90105-06111	B - 7	90183-06023	B - 8
5XE-23144-L0	D - 4	3XJ-24380-00	D - 7	5UN-2585B-00	E - 4	5XE-27421-01	E - 3		D - 14	90185-08008	D - 12
1C3-23145-M0	D - 4	3JD-24500-10	D - 7	5MV-25867-00	E - 2	1C3-27491-50	D - 14	90105-06112	D - 15	90185-08009	C - 8
5XE-23146-M0	D - 4	4X8-24512-00	D - 7	5NY-25868-00	E - 2	5ET-28166-10	C - 9	90105-06118	B - 7	90185-10012	D - 2
1AE-23147-00	D - 4	5MV-24514-00	B - 11	1C3-25872-90	E - 2	1C3-8231U-10	E - 7	90105-08071	C - 3	90185-14010	C - 14
1C3-23147-L0	D - 4	3AJ-24534-01	D - 7	1C3-25873-00	E - 4	1C3-82320-00	E - 7	90105-08085	C - 8	90185-16002	C - 13
1C3-2314F-M0	D - 4	5NY-24610-00	D - 7	1C3-25875-50	D - 11	8DG-82370-00	E - 7	90105-08132	C - 8	90185-20002	D - 13
1C3-2314H-10	D - 6	1C3-2470F-50	D - 9	1C3-25876-50	E - 4	1C3-82509-10	E - 7	90105-08133	C - 8	90201-03313	B - 8
1C3-2314J-10	D - 6	5NY-24728-10	D - 9	1C3-25886-50	E - 4	5XE-82911-00	E - 6	90105-08134	D - 3	90201-05021	B - 4
5XE-23153-L0	D - 4	1C3-24770-51	D - 9	5MV-2589F-00	E - 2	5TG-82913-00	E - 6		D - 6	90201-06032	C - 10
2HH-23158-L0	D - 4	5NY-25104-00	D - 10	5UN-25914-00	D - 14	5MV-83912-00	E - 6	90105-08137	D - 11	90201-06033	B - 12
1C3-2316A-N0	D - 4	5NY-25111-00	D - 10	5DH-25914-50	D - 14	1C3-83922-50	E - 2	90105-10175	C - 8		C - 10
1C3-2316A-S0	D - 4	5NY-25117-00	D - 10	3SP-25914-51	D - 11	5HD-83951-00	E - 6	90105-10176	C - 9	90201-06060	C - 2
1C3-23170-R0	D - 4	1C3-25181-10	D - 10	5DH-25916-00	D - 11	1C3-83976-00	E - 6	90109-06034	E - 6	90201-06077	B - 12
1C3-23170-S0	D - 4	5NY-25183-00	D - 10		D - 14	5LP-84126-10	E - 6	90109-06193	C - 6	90201-06078	B - 12
5XE-23171-L0	D - 4	5NY-25186-00	D - 10	3JD-25917-00	D - 11	1C3-85540-10	E - 7	90109-067F4	B - 8	90201-06086	B - 12
5DH-23183-00	C - 15	5HD-25304-00	D - 12		D - 14	1C3-85546-00	E - 7	90109-08078	D - 12	90201-06571	B - 7
509-23184-L0	C - 15	5TJ-2530S-80	D - 13	5DH-25919-00	D - 11	1C3-85550-01	E - 5	90111-06059	E - 4	90201-08043	C - 8
1C3-23188-L0	D - 4	5ET-25311-00	D - 12	5DH-25919-50	D - 14	1C3-85560-10	E - 5	90111-08028	C - 8	90201-08044	E - 3
1C3-23188-N0	D - 4	5ET-25317-00	D - 12	8CR-25924-00	D - 14	5NY-W0041-00	E - 2	90116-08027	B - 2	90201-08045	C - 8
1C3-23188-P0	D - 4	4XM-25364-00	D - 12	3SP-25926-51	D - 11	5UN-W0042-50	E - 4	90116-08028	B - 2	90201-08048	D - 12
1C3-23188-R0	D - 4	1C3-25381-90	D - 13	5DH-25933-00	D - 11	5MV-W0045-01	D - 11	90116-08031	B - 2	90201-08055	C - 9
1C3-23190-L0	D - 4	1C3-25388-50	D - 13	1UY-25937-51	D - 11	1C3-W0046-50	D - 14	90119-06147	C - 10	90201-080H1	C - 3
1C3-23340-M0	D - 6	1C3-25389-00	D - 13		D - 14	3JD-W0047-00	D - 11	90119-06149	C - 10	90201-080L8	B - 2
3SP-23356-L0	D - 6	4XM-25394-00	D - 12	1C3-26111-90	D - 15	5UN-W0047-50	D - 14	90119-06151	D - 3	90201-08512	B - 6
5XE-23389-00	D - 6	5SF-25394-00	D - 10	5XC-26124-90	E - 6	1UY-W0048-50	D - 11	90119-08095	C - 12	90201-10032	E - 3
4EW-23416-00	D - 3	1C3-25447-00	D - 12	5XC-26143-90	E - 6		D - 14	90122-06005	B - 8	90201-12020	C - 7
1C3-23435-50	D - 3	1C3-25448-00	D - 12	4XM-26240-00	D - 15	5UN-W0057-00	D - 11	90149-06074	C - 4	90201-12028	D - 3

NUMERICAL INDEX

PART NO.	GRID NO.	PART NO.	GRID NO.	PART NO.	GRID NO.	PART NO.	GRID NO.	PART NO.	GRID NO.	PART NO.	GRID NO.
90201-127E1	E - 5	90401-10172	E - 2	91312-05012	B - 2	93306-07202	D - 12	94330-21084	D - 10	99530-08016	B - 15
90201-14020	C - 14		E - 4	91312-06045	B - 14	93306-20351	C - 4	94416-21005	D - 10	99530-10116	B - 14
90201-150U6	B - 4	90430-06014	B - 6	91312-06055	B - 14	93306-20447	C - 4	94418-19003	D - 12	99590-10114	B - 2
90201-16018	C - 13		B - 15	91312-06065	B - 14	93306-27212	D - 12	94681-68001	D - 13	99590-17016	B - 14
90201-171G4	C - 2	90430-10005	E - 2	91312-06075	B - 14	93306-37204	B - 5	94702-00193	B - 2	9Y581-92111	D - 13
90201-175F6	C - 2		E - 4	91402-20012	E - 3	93306-90408	C - 6	94709-00193	B - 2		
90201-20020	D - 13	90430-10188	B - 14	91402-25015	E - 3	93306-90409	D - 10	95022-06010	B - 6		
90201-20611	C - 3	90445-08605	B - 14	91A20-05065	B - 7	93310-21510	B - 5	95022-06012	B - 12		
90201-21014	C - 13	90445-09220	D - 7	92012-06010	B - 12		E - 9	95022-06014	B - 12		
90201-22555	C - 4	90445-09251	D - 7	92012-06012	B - 15	93310-22539	C - 3	95022-06020	B - 8		
90201-24016	D - 3	90445-111J0	D - 7	92502-06030	B - 15	93310-52238	B - 5		C - 7		
90201-286K9	D - 3	90450-22001	B - 7	92902-03100	B - 8		E - 9	95022-06025	B - 6		
90202-05193	D - 7	90450-25001	B - 7	92902-05600	B - 3	93315-11040	C - 3		B - 12		
90209-06096	B - 8	90450-28001	B - 7	92902-06100	D - 9	93315-32166	C - 13		B - 15		
90209-16011	C - 13	90450-54007	B - 8	92902-06600	B - 15	93317-22262	C - 13	95022-06030	B - 12		
90209-18135	C - 4	90450-70002	B - 8	92902-10200	C - 8	93332-00068	D - 3		B - 15		
90209-20008	C - 4	90461-10136	B - 14		D - 2	93332-00081	D - 6	95022-06040	B - 15		
90209-22326	B - 5	90464-13073	E - 6	92904-05600	C - 8	93340-21008	C - 3	95022-06050	B - 15		
	E - 9	90464-13077	E - 6	93102-08004	B - 6	93340-21505	B - 4	95022-06065	B - 6		
90209-23012	C - 4	90464-15195	E - 7	93102-08307	B - 6	93342-22217	C - 13		B - 15		
90215-16289	C - 3	90465-13275	D - 7	93102-10008	C - 3	93410-22039	C - 4	95022-08040	C - 8		
90215-20003	C - 5		E - 7	93102-12224	C - 7	93410-26067	C - 4	95022-10016	B - 14		
90240-08120	E - 3	90467-090A2	B - 7	93102-17263	C - 2	93440-07182	B - 6	95602-10200	D - 2		
90240-10004	E - 3	90467-100A1	D - 7	93102-20485	B - 5		C - 3	95602-12200	D - 3		
90267-32070	B - 8	90467-13062	B - 2	93102-22419	B - 5	93450-16068	B - 5	95701-06500	E - 2		
90280-03017	B - 5	90468-16001	E - 3	93102-26468	D - 10		E - 9	95702-06500	D - 11		
90387-04003	D - 15	90468-26048	C - 2	93102-28012	C - 5	93507-16020	B - 4	97002-05012	B - 4		
90387-06009	C - 10	90480-08608	D - 13	93104-08040	B - 2	93507-32009	C - 2	97002-05016	B - 3		
90387-06039	B - 13	90480-15528	B - 7		B - 4	93511-32027	C - 3	97002-06012	D - 9		
90387-06065	B - 7	90480-16404	B - 13	93104-12003	C - 7	93603-12007	B - 6	97004-05012	C - 8		
90387-06090	C - 10	90480-16561	B - 12	93106-22002	C - 13	93603-14240	B - 4	97022-06012	C - 2		
90387-06104	D - 6	90480-17004	B - 13	93106-30001	D - 12	93604-10011	B - 6	97702-60016	C - 10		
90387-06121	B - 12	90480-18549	D - 7	93106-30045	D - 12		B - 15	98502-03006	B - 8		
90387-063G3	B - 12	90501-052G5	C - 7	93109-21001	C - 14	93608-33002	C - 7	98502-05010	E - 4		
90387-08032	B - 6	90501-12081	C - 2	93109-25001	C - 13	9383B-13218	C - 5	98502-05012	B - 4		
90387-08041	C - 8	90501-23598	C - 3	93109-28043	C - 13	94108-21012	D - 10	98502-05014	B - 11		
90387-085E1	B - 4	90501-300A0	B - 4	93210-11073	E - 3	94108-21015	D - 10	98502-06030	B - 15		
90387-086N4	C - 8	90506-16007	E - 3	93210-15171	C - 2	94108-2112Y	D - 10	98507-03008	D - 7		
90387-08785	B - 3	90506-20018	B - 12	93210-16314	B - 14	94110-19009	D - 12	98507-04008	B - 9		
90387-107T9	B - 4	90508-16134	B - 3	93210-19123	B - 15	94110-19012	D - 12	98507-04014	B - 9		
90387-14005	C - 14	90508-261B7	C - 6	93210-63442	B - 2	94110-1913B	D - 12	98680-04510	D - 15		
90387-152F2	B - 4	90508-26450	C - 2	93210-90785	B - 2	94209-21229	D - 10	98680-04516	D - 15		
90387-16010	C - 13	90508-28015	E - 3	93300-60801	B - 4	94210-19222	D - 12	98702-06025	D - 7		
90387-172K2	C - 3	90508-28018	E - 3		B - 6	94210-19224	D - 12	98706-04012	E - 2		
90387-18010	C - 13	90508-29020	C - 7	93300-60814	B - 6	94227-21101	D - 10	98902-05016	B - 2		
90387-18012	C - 13	90560-12280	C - 7	93300-60839	C - 8	94309-21161	D - 10	98902-06025	D - 7		
90387-22004	C - 5	91312-04006	B - 4	93306-00326	C - 4	94316-19156	D - 12	99009-17400	C - 2		
90387-227H7	D - 15	91312-04010	B - 2	93306-00442	C - 4	94321-19135	D - 12	99009-45500	D - 12		